

FR

Visiophone vidéo couleur 7"

2 fils

réf. 340100



GUARANTIE 3 ans



ÉCRAN 7"



VISION
NOCTURNE



SONNERIES



2 FILS



PORTÉE
100M

A - CONSIGNES DE SÉCURITÉ

1 - INTRODUCTION

Cet interphone vidéo associe deux modules : un moniteur récepteur et une platine de rue facile à installer et à utiliser.

Caractéristiques principales :

- Réception vidéo couleur : lorsqu'un visiteur appuie sur la touche d'appel de la platine de rue, ceci transmet immédiatement l'image à l'écran et un carillon signale sa présence.
- Protection en cas de court-circuit
- Protection en cas d'inversion de polarité
- Réglage automatique de l'exposition : la caméra vidéo s'ajuste automatiquement aux conditions d'éclairage ambiant.
- Permet de contrôler deux accès (serrure et commande automatique).
- La vision infrarouge intégrée dans la caméra vidéo permet d'identifier les visiteurs sans besoin d'éclairage supplémentaire.
- Ouverture de la porte et d'une commande : en appuyant sur les touches du moniteur, vous pouvez contrôler une serrure électrique et un contact sec pour la commande automatique (non fournie).

IMPORTANT : Cette notice doit être lue attentivement avant l'installation. En cas de problème, les techniciens de notre Hotline sont à votre disposition pour tout renseignement.

ATTENTION : toute erreur de branchement peut causer des dommages à l'appareil et annuler la garantie.

2 - ENTRETIEN ET NETTOYAGE

Avant d'installer votre interphone, il est important de vérifier les points suivants :

- Ne pas l'installer en cas d'humidité, de température, de risque de corrosion ou de poussière extrêmes.
- Ne pas exposer directement le moniteur à la lumière du soleil, à la pluie ou à une forte humidité.
- Ne pas brancher l'appareil à une multiprise ou à une rallonge.
- Ne pas installer à proximité d'autres appareils électroniques, comme un ordinateur, une télévision ou un enregistreur vidéo.
- Ne pas installer à proximité de produits chimiques acides, d'ammoniaque ou d'une

source d'émission de gaz toxiques.

- Ne pas nettoyer avec un produit abrasif ou corrosif. Utiliser un chiffon légèrement humide avec de l'eau savonneuse.
- Débrancher l'appareil s'il n'est pas utilisé pendant une longue durée.
- Ne pas brancher l'appareil aux installations nationales de télécommunication.

3 - RECYCLAGE



Ce logo signifie qu'il ne faut pas jeter les appareils hors d'usage avec les ordures ménagères.

Les substances dangereuses qu'ils sont susceptibles de contenir peuvent nuire à la santé et à l'environnement. Faites reprendre ces appareils par votre distributeur ou utilisez les moyens de collecte sélective mis à votre disposition par votre commune.



Pour en savoir plus :
www.quefairedemesdechets.fr

B - DESCRIPTION DU PRODUIT

1 - CONTENU DU KIT

1 x 1

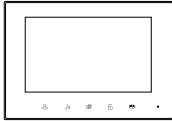

2 x 1



3 x 1

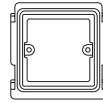

4 x 5



5 x 5



6 x 3



7 x 1



1	Moniteur
2	Platine de rue
3	Support mural pour moniteur
4	Cheilles (2 pour le moniteur, 3 pour platine de rue)

5	Vis de fixation (2 pour le moniteur, 3 pour platine de rue)
6	Connecteur platine de rue vers moniteur/ gâche électrique/motorisation de portail
7	Adaptateur secteur

C - INSTALLATION

La hauteur d'installation recommandée est située à environ 160 cm du sol pour la platine de rue et 150 cm du sol pour l'unité interne.

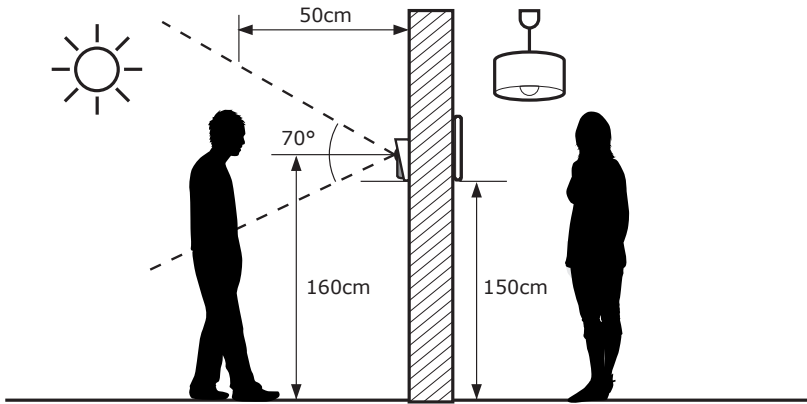

ATTENTION : Pour des raisons évidentes de sécurité, les branchements ne doivent être effectués qu'après avoir coupé l'alimentation électrique.

1 - INSTALLATION DE LA PLATINE DE RUE

Fixer la casquette de la platine de rue sur votre pilier à l'aide de vis et chevilles adaptées au support (les vis et chevilles fournies conviennent pour des murs en matériau plein).

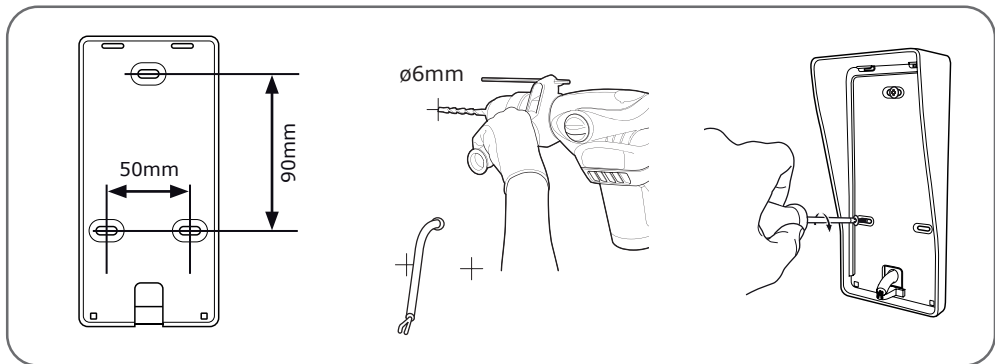

Après avoir effectué les branchements de la platine de rue (voir paragraphe connexions), placer celle-ci dans sa casquette.

C - INSTALLATION

Visser ensuite la platine de rue sur la casquette à l'aide de la vis fournie.

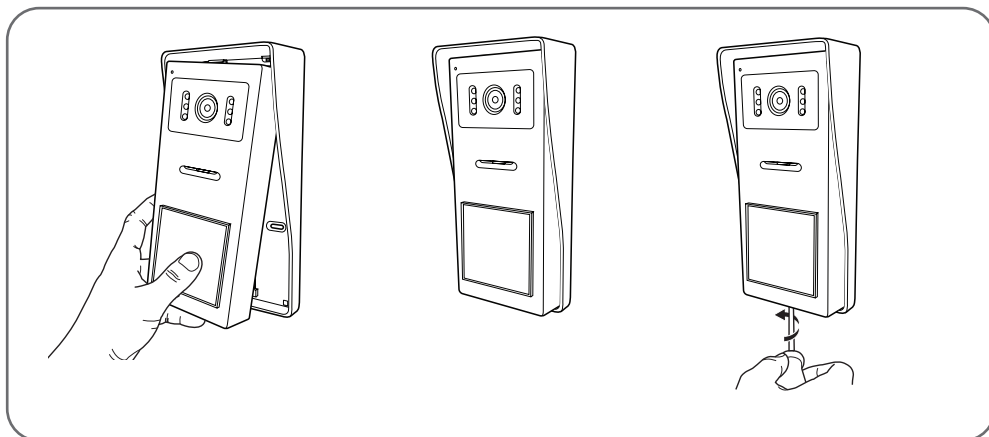

Mettre en place l'étiquette nominative.

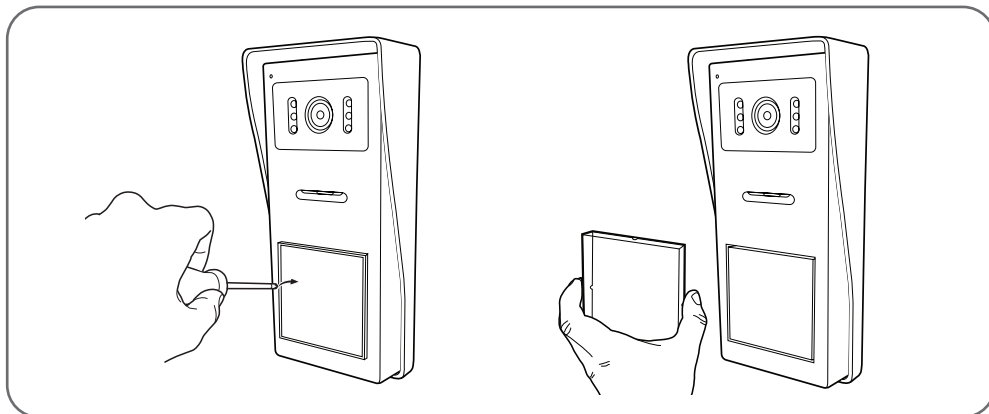

C - INSTALLATION

2 - INSTALLATION DU MONITEUR

Fixer le support mural au mur à l'aide de vis et chevilles adaptées au support (les vis et chevilles fournies conviennent pour des murs en matériaux pleins).

Après avoir effectué les branchements du moniteur (voir paragraphe «connexions»), fixer le moniteur sur son support.

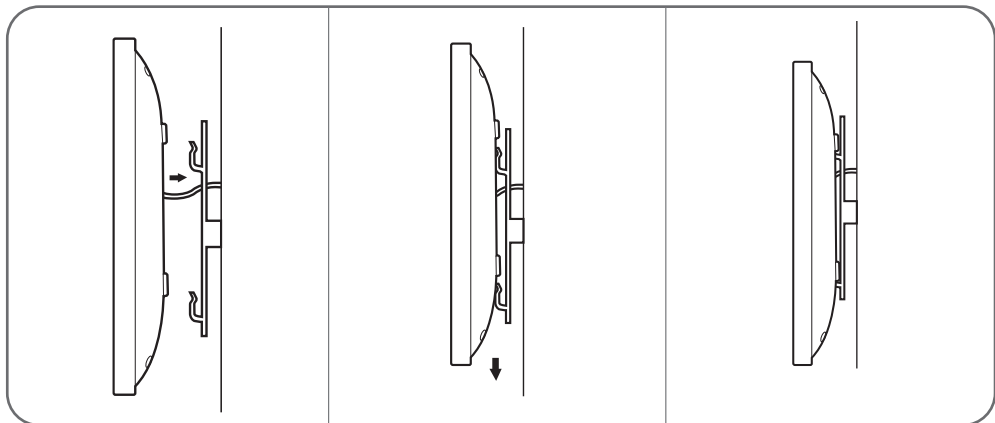
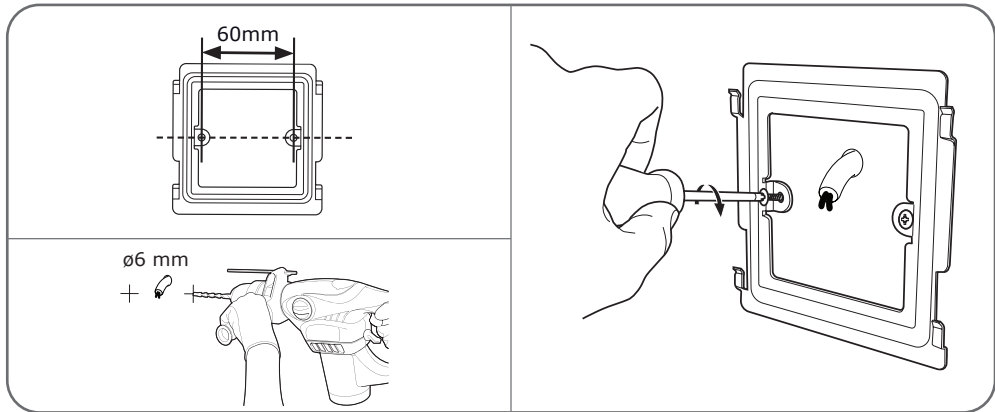

3 - LES CONNEXIONS

- Ne multipliez pas les dominos ou raccords sur le fil de liaison entre la platine de rue et le moniteur
- Eloignez le fil de liaison entre la platine de rue et le moniteur de plus de 50cm de toute perturbation électromagnétique (câble 230V, appareil WiFi, four à micro-ondes, etc.)
- Vous pouvez connecter et utiliser une gâche électrique (non fournie) avec votre platine de rue, avec ou sans mémoire mécanique.

C - INSTALLATION

Entre le moniteur et la platine de rue (100m maximum)

Afin de s'assurer d'une bonne qualité audio et vidéo, il est conseillé de ne pas utiliser plus de 100m de câble entre l'interphone et la platine de rue. Bien raccorder les fils comme suit (une inversion de branchement peut endommager la platine de rue).

La section du câble à utiliser dépend de sa longueur :

Longueur du câble	Section à utiliser
De 0 à 50m	0,75mm ²
De 50m à 100m	1,5mm ²

Entre la platine de rue et une gâche électrique (non fournie)

Utiliser une gâche 12V/1,1A maximum avec ou sans mémoire mécanique.

Pour la connexion entre la platine de rue et la gâche, utiliser du câble de type :

Longueur du câble	Section à utiliser
De 0 à 50m	0,75mm ²

Entre la platine de rue et une motorisation de portail (non fournie)

Section à utiliser : 0,75mm² mini

3.1 - BRANCHEMENT ENTRE LE MONITEUR ET LA PLATINE DE RUE

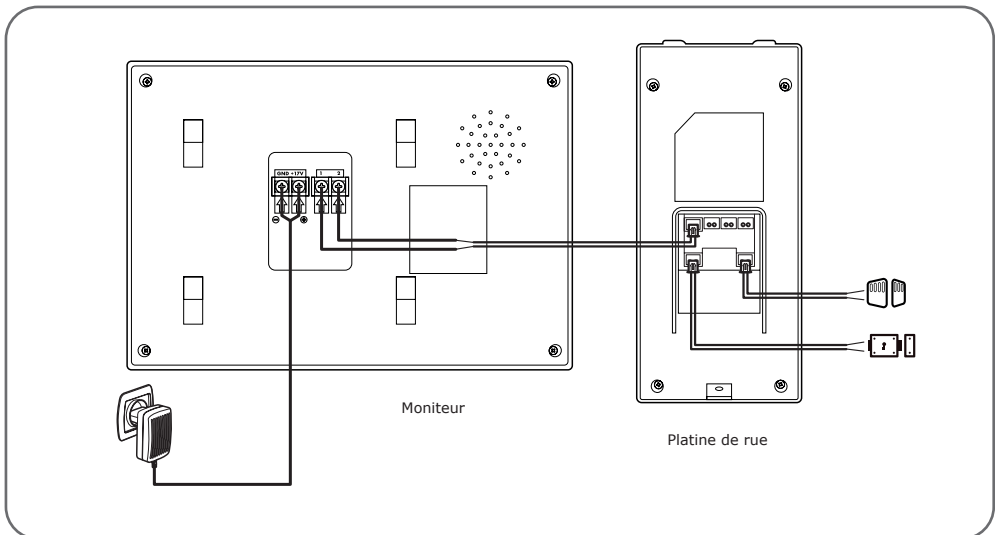

IMPORTANT : connectez la sortie de commande portail directement au contact d'ouverture/fermeture de la commande automatique (entrée de commande filaire d'une motorisation de portail).

Votre portier vidéo est équipé de la fonction Polarity protect: le sens de branchement des deux fils du moniteur, de la gâche électrique ou du portail est sans importance.



D - UTILISATION

1 - IDENTIFIER LE VISITEUR ET LUI PARLER

Le visiteur appuie sur la porte nom de la platine de rue :



Le carillon se déclenche via le haut-parleur du moniteur qui active la caméra vidéo de la platine de rue. Si le visiteur se situe dans le champ de la caméra, son image apparaîtra sur le moniteur pendant 30 secondes. À la fin des 30 secondes, le moniteur repassera en mode veille.

Pour parler au visiteur, appuyez sur la touche . Pour terminer la conversation et désactiver la platine de rue, appuyez sur la touche .

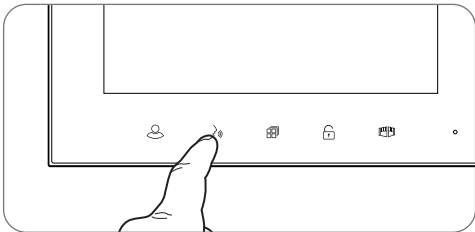

2 - ACTIVER LA PLATINE DE RUE DEPUIS LE MONITEUR



Pour identifier un visiteur sans qu'il sache qu'il est observé ou pour regarder tout simplement dehors,

appuyez sur la touche  : l'image de la platine de rue apparaît alors à l'écran pendant 60 secondes.

Si vous souhaitez communiquer directement avec l'extérieur, appuyez sur la touche  une fois la caméra vidéo externe affichée.

Cette fonction particulièrement utile vous permet d'observer le visiteur, même s'il n'a pas sonné.

3 - OUVERTURE D'UNE SERRURE ÉLECTRIQUE ET D'UNE COMMANDE AUTOMATIQUE

Si l'appareil est équipé d'une serrure électrique et/ou d'une commande automatique (voir paragraphe «Connexion»), appuyez sur la touche  (pour la serrure) ou sur  (pour la commande automatique) pour laisser entrer le visiteur.

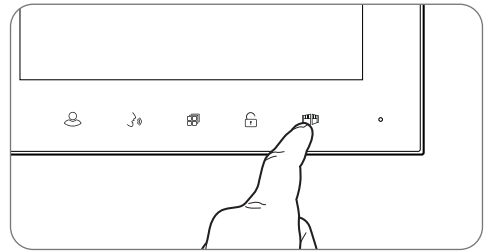
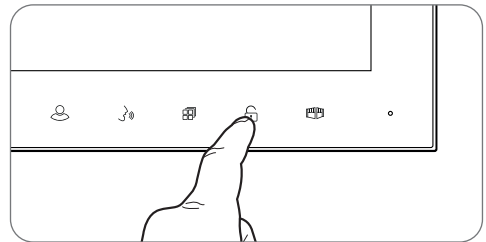

Attention, il est nécessaire que l'écran soit allumé pour que les commandes contact sec et sortie alimentée soient opérationnelles. Si l'écran est éteint, il est nécessaire de l'allumer grâce au bouton .

D - UTILISATION



4 - PARAMÈTRES SUR LE MONITEUR

Pendant que l'écran est allumé, appuyez sur la touche  pour afficher l'écran suivant :



Naviguez dans les sous-menus en appuyant sur les touches .





• BRT :

Luminosité : appuyez sur les touches  et  pour réduire ou augmenter le niveau de luminosité de l'image.



• CON :

Contraste : appuyez sur les touches  et  pour réduire ou augmenter le niveau de contraste de l'image.



• COL :

Couleur : appuyez sur les touches  et  pour réduire ou augmenter le niveau de saturation de l'image.

• CALL :

Volume microphone : appuyez sur les touches  et  pour augmenter ou réduire le volume du microphone.

• INCOME :

Volume carillon : appuyez sur les touches  et  pour réduire ou augmenter le volume de la sonnerie.

• RING :

Sélectionner le carillon : appuyez sur les touches  et  pour sélectionner la sonnerie souhaitée.

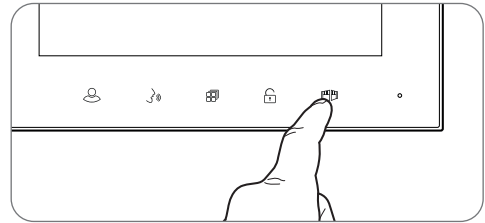

Une fois sur le sous-menu RING, appuyez sur la touche  pour sortir.

E - INFORMATIONS TECHNIQUES ET LÉGALES

1 - CARACTERISTIQUES TECHNIQUES

MONITEUR	
Écran	Couleur 7 pouces LCD extra plat
Standard vidéo	PAL/NTSC
Résolution	800 x 480
Alimentation	Avec adaptateur secteur 230 VAC 50 Hz/17 VDC 1,5 A fourni
Protection	Protection en cas de court-circuit et en cas d'inversion de polarité
Système de transmission (audio et vidéo)	2 fils
Plage de température de fonctionnement idéale	-20 °C à 50 °C
Taux d'humidité max.	85 %
Nombre de sonneries	6
Dimension	209 x 144 x 22 cm

PLATINE DE RUE	
Caméra vidéo	CMOS 420TVL
Objectif	Angle de vision horizontal 100°
Alimentation	13VDC fournie par le moniteur
Consommation max.	200 mA
Luminosité	min 0 lux
Vision nocturne	De 0,5 à 1 m
Dimension	157 x 72 x 27 mm
Indice de protection	IP44

2 - GARANTIE

- Ce produit est garanti 3 ans, pièces et main d'œuvre, à compter de la date d'achat. Il est impératif de garder une preuve d'achat durant toute cette période de garantie.
- La garantie ne couvre pas les dommages causés par négligence, chocs ou accidents.
- Toute intervention sur l'appareil annulera la garantie.
- Ne pas sectionner ou rallonger le fil de l'adaptateur secteur sous peine d'annulation de la garantie.

3 - ASSISTANCE ET CONSEILS

- Malgré tout le soin que nous avons porté à la conception de nos produits et à la réalisation de cette notice, si vous rencontrez des difficultés

lors de l'installation de votre produit ou des questions, il est fortement conseillé de contacter nos spécialistes qui sont à votre disposition pour vous conseiller.

- En cas de problème de fonctionnement pendant l'installation ou après quelques jours d'utilisation, il est impératif de nous contacter devant votre installation afin que l'un de nos techniciens diagnostique l'origine du problème car celui-ci provient certainement d'un réglage non adapté ou d'une installation non conforme.

Contactez les techniciens de notre service après-vente au :

0 892 701 369 Service 0,35 € / min
+ prix appel

Du lundi au vendredi de 9H à 12H et de 14H à 18H.

EN Colour videophone 7" 2-wire

ref. 340100



3-year WARRANTY



7" SCREEN



NIGHT
VISION



MELODIES



2-WIRE



100M
RANGE

A - SAFETY INSTRUCTIONS

1 - INTRODUCTION

This video intercom system pairs two modules: a receiver-monitor and an easy-to-install and use intercom panel.

Key features:

- Colour video reception: when a visitor touches the intercom panel call button, the panel immediately transmits the image to the screen and a chime indicates the visitor's presence.
- Short-circuit protection
- Reverse polarity protection
- Automatic exposure correction: the video camera automatically adjusts its exposure to match the ambient light conditions.
- Enables control over two entrances (lock and automatic control system).
- Integrated infrared vision enables the video camera to identify visitors without needing additional light.
- Opening the door and a control system: by pressing buttons on the monitor, you can control an electric lock and a dry contact for an automatic control system (not included).

IMPORTANT: These instructions should be read carefully prior to installation. In the case of any problems, our Hotline technicians are at your service to provide you with any information you may need.

WARNING: any connection error may cause damage to the device and void the warranty.

2 - MAINTENANCE AND CLEANING

Before installing the intercom, it is important to check the following points:

- Do not install in cases of extreme humidity, temperatures, corrosion risk or dust.
- Do not expose the monitor to direct sunlight, rain or high humidity.
- Do not plug the device into a multi-socket plug adaptor or extension cord.
- Do not install near other electronic devices such as computers, televisions or video recorders.
- Do not install near acidic chemicals, ammonia or sources of toxic gases.
- Do not clean with abrasive or corrosive products. Use a damp cloth with soapy water.
- Unplug the device if it is not being used for an extended period of time.

- Do not plug the device into national telecommunications installations.

3 - RECYCLING



This logo denotes that devices no longer in use should not be disposed of as household waste.

They are likely to contain hazardous substances which are dangerous to both health and the environment. Return the equipment to your local distributor or use the recycling collection service provided by your local council.



B - PRODUCT DESCRIPTION

1 - CONTENTS OF THE KIT

1 x1

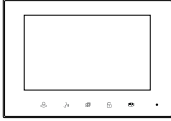

2 x1



3 x1

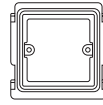

4 x5



5 x5



6 x3



7 x1



1	Monitor
2	Intercom panel
3	Monitor wall bracket
4	Dowels (2 for the monitor, 3 for the intercom panel)

5	Screws (2 for the monitor, 3 for the intercom panel)
6	Intercom panel to monitor/electric strike plate/automated gate connector
7	Mains adaptor

C - INSTALLATION

The recommended installation height for the intercom panel is about 160 cm from the ground and 150 cm from the floor for the indoor unit.

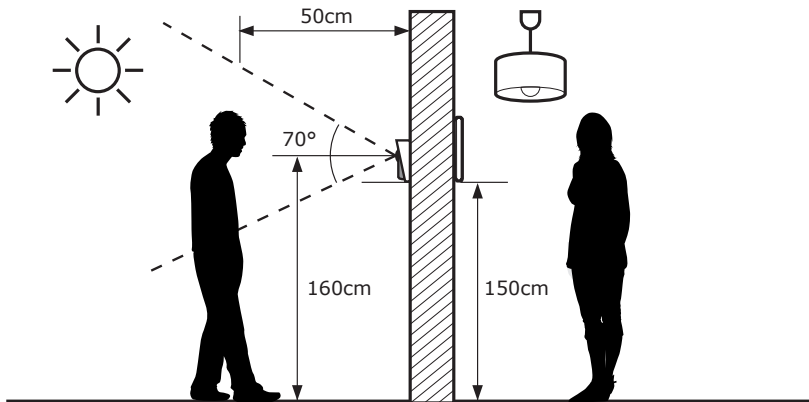

NOTE: For obvious safety reasons, the connections must only be made after shutting off the power supply.

1 - INTERCOM PANEL INSTALLATION

Attach the intercom panel hood to your support using the screws and wall plugs suited to the support (the screws and plugs supplied are suitable for solid walls).

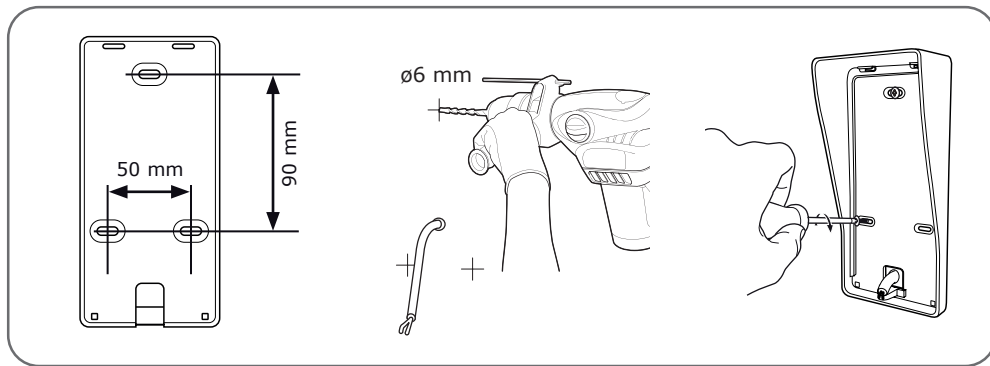

After making the connections on the intercom panel (see the connections paragraph), put the intercom panel into the hood.

C - INSTALLATION

Then screw the intercom panel to the hood with the screw provided.

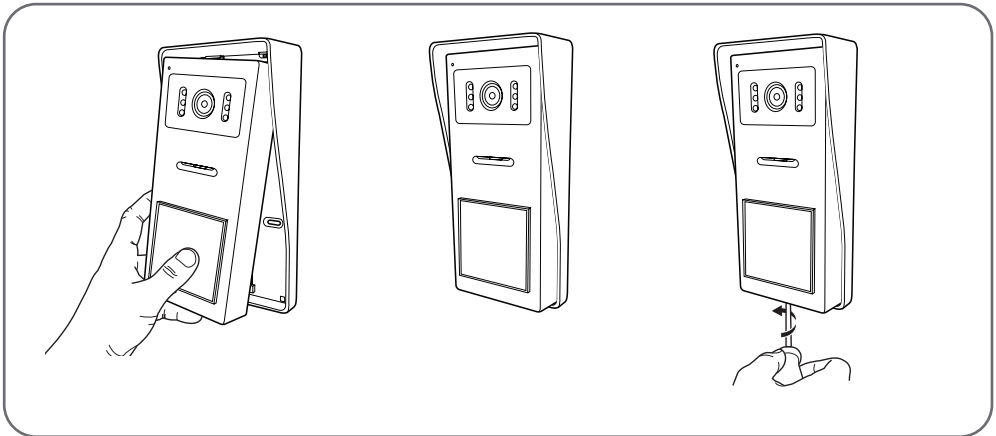

Put on the name label.

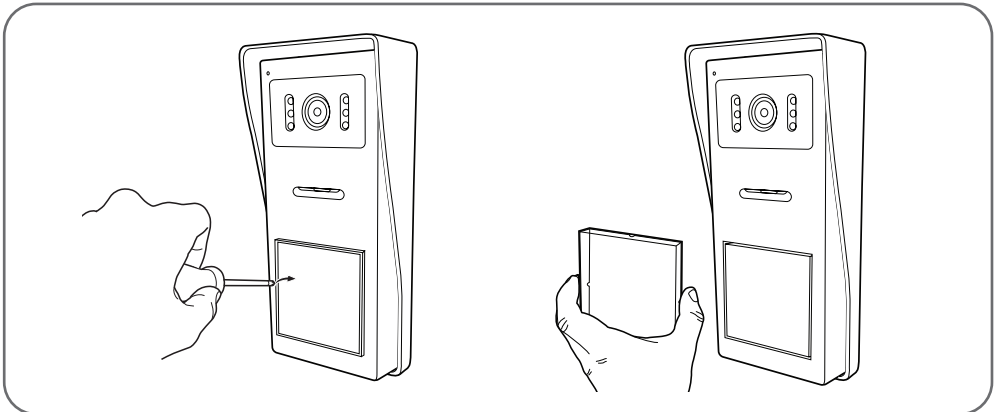

C - INSTALLATION

2 - INSTALLING THE MONITOR

Attach the wall mount to the wall using the screws and wall plugs suited to the support (the screws and plugs supplied are suitable for solid walls).

After connecting the monitor (refer to the "connections" paragraph), fit the monitor onto its support.

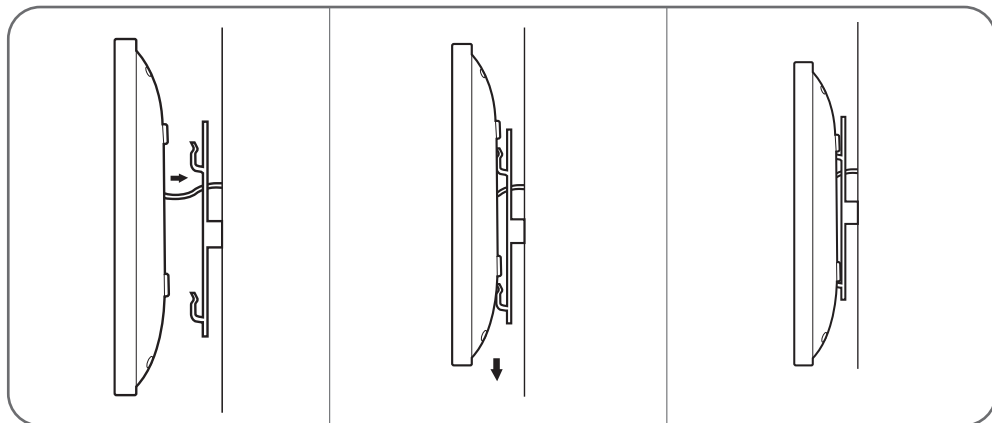
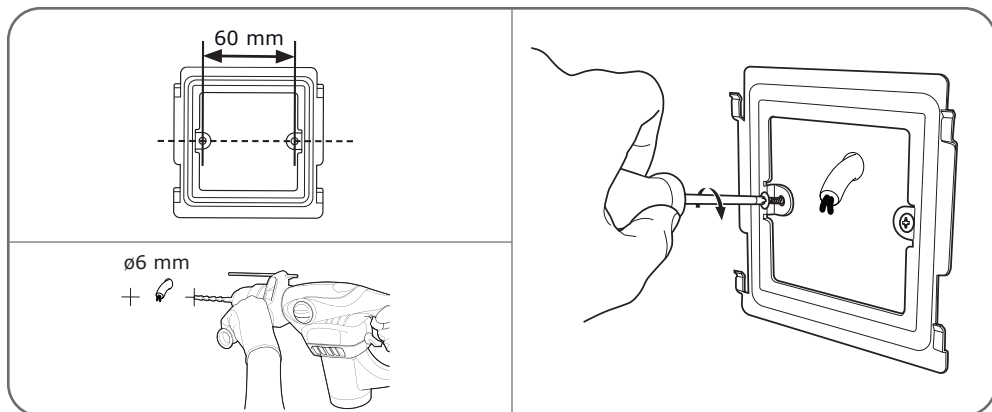

3 - CONNECTIONS

- Do not increase the number of insulating screw joints or connectors on the connecting wire between the intercom panel and the monitor
- Keep the connecting wire between the intercom panel and the monitor more than 50 cm away from any electromagnetic interference (230 V cable, WiFi device, microwave ovens, etc.)
- You can connect and use the electric strike plate (not provided) with your intercom panel, with or without mechanical memory.

C - INSTALLATION

Between the monitor and the intercom panel (100m maximum)

To ensure good audio and video quality, it is recommended to not use more than 100m of cable between the intercom and the intercom panel. Connect the wires as follows (incorrect wiring can damage the intercom panel).

The cable's length determines which cable section is to be used:

Cable length	Section to use
0 to 50 m	0.75 mm ²
50 m to 100 m	1.5 mm ²

Between the intercom panel and an electric strike plate (not included)

Use a 12V/1.1A maximum electric latch with or without mechanical memory.

For the connection between the intercom panel and the door release, use a cable of this kind:

Cable length	Section to use
0 to 50 m	0.75 mm ²

Between the intercom panel and the automated gate (not included)

Section to use: Min. 0.75 mm²

3.1 - CONNECTION BETWEEN THE MONITOR AND THE INTERCOM PANEL

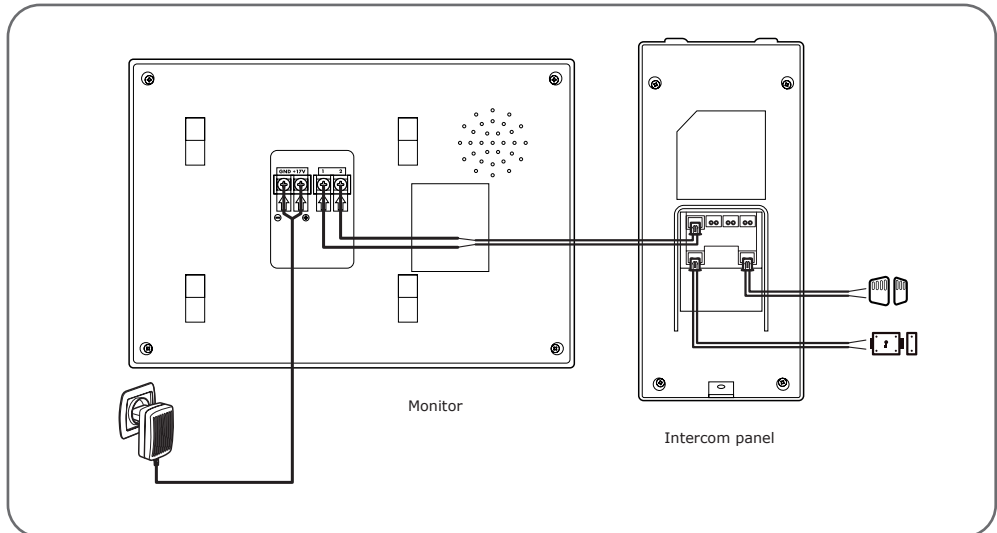

IMPORTANT: connect gate control output directly to the opening/closing contact of the automatic control system (automated entryway wired control system input).

Your gate video intercom system is equipped with the Polarity Protect feature: you can connect the 2 wires for the monitor, electric strike plate and gate in any direction.



D - USING THE PRODUCT

1 - IDENTIFY AND SPEAK TO THE VISITOR

The visitor presses the intercom panel's name plate:



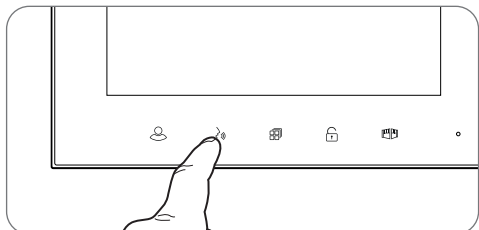

The chime sounds through the monitor's speaker and the intercom panel's video camera is activated. If the visitor is positioned within the camera's field of vision, their image will appear on the monitor for 30 seconds. After 30 seconds, the monitor will return to sleep mode.

To speak with the visitor, press the  button. To end the conversation and deactivate the intercom panel, press the  button.





2 - ACTIVATE THE INTERCOM PANEL FROM THE MONITOR

To identify a visitor without them knowing they are being observed or to simply look outside, press the  button: the view from the intercom panel will then appear on the screen for 60 seconds.

If you wish to communicate directly with the outside, press once on the  button when the external video camera is displayed.

This particularly useful feature allows you to observe the visitor, even if they haven't rung.

3 - OPENING AN ELECTRIC LOCK AND AN AUTOMATIC CONTROL SYSTEM

If the device is equipped with an electric lock and/or an automatic control system (see "Connection" paragraph), press the  button (for the lock) or the  button (for the automatic control system) to let a visitor enter.

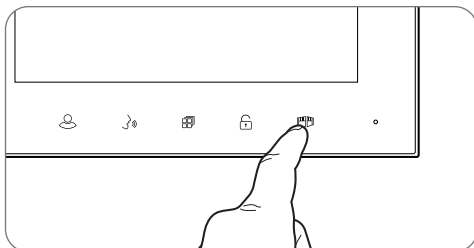
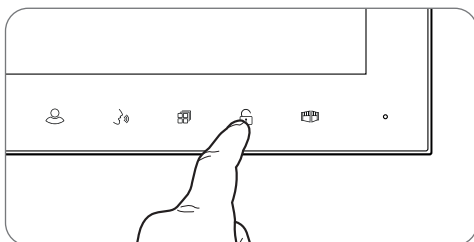

Warning: the screen must be switched on before the dry contact and powered output controls can function. If the screen is off, it must be switched on using the button .

D - USING THE PRODUCT



4 - MONITOR SETTINGS

With the screen is on, press the  button to display the following screen:

Browse the sub-menus by pressing on buttons .

BRT.	■■■■■■■■■■■■■■■■■■■■20
CON.	■■■■■■■■■■■■■■■■■■■■18
COL.	■■■■■■■■■■■■■■■■■■■■18
CALL.	■■■■■■■■■■■■■■■■■■■■21
INCOME.	■■■■■■■■■■■■■■■■■■■■	05
RING.	■■■■■■■■■■■■■■■■■■■■	05



• BRT:

Brightness: press the  and  buttons to decrease or increase the brightness level of the image.

• CON:

Contrast: press the  and  buttons to decrease or increase the contrast level of the image.

• COL:



Colour: press the  and  buttons to decrease or increase the saturation level of the image.

• CALL:

Microphone volume: press the  and  buttons



to increase or decrease the microphone volume.

• INCOME:

Chime volume: press the  and  buttons

to decrease or increase the ring volume.

• RING:

Choose the chime: press the  and  buttons

to select the desired tone.

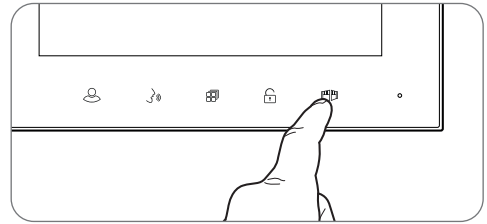

Once in the RING sub-menu, press the  button to exit.

E - TECHNICAL AND LEGAL INFORMATION

1 - TECHNICAL CHARACTERISTICS

MONITOR	
Screen	Ultra-flat 7" colour LCD
Video standard	PAL/NTSC
Resolution	800 x 480
Power supply	With 230 VAC 50 Hz/17 VDC 1.5 A mains adapter (included)
Protection	Short circuit and reverse polarity protection
Transmission system (audio and video)	2-wire
Ideal operating temperature range	-20 °C to 50 °C
Max. degree of humidity	85%
Number of doorbell melodies	6
Dimensions	209 x 144 x 22 cm

INTERCOM PANEL	
Video camera	CMOS 420TVL
Lens	100° horizontal viewing angle
Power supply	13 VDC supplied by the monitor
Max. consumption	200 mA
Brightness	min. 0 lux
Night vision	0.5 to 1 m
Dimensions	157 x 72 x 27 mm
Protection rating	IP44

2 - WARRANTY

- This product is guaranteed for parts and labour for 3 years from the date of purchase. Proof of purchase must be retained for the duration of the warranty period.
- The warranty does not cover damage caused by negligence, knocks or accidents.
- The warranty will be void if the device is tampered with.
- Do not cut or extend the wire of the mains adapter or the warranty will be void.

3 - HELP AND SUGGESTIONS

- If, despite the care we have taken in designing our products and drafting these instructions, you do encounter difficulties when installing your product or you have any questions, we

recommend you contact one of our specialists who will be glad to help.

- If you encounter operating problems during the installation or a few days afterwards, it is essential that you are in front of your installation when contacting us, so that one of our technicians can diagnose the source of the problem, as it will probably be the result of a setting that is incorrect or an installation that is not to specification.

Contact our after sales service team technicians:

0 892 701 369 Service 0,35 € / min
+ prix appel

Monday to Friday, 9am to 12pm, and 2pm to 6pm.

NL Kleuren videofoon 7" 2 draden

ref. 340100



GARANTIE 3 jaar



SCHEM 7"



NACHT
ZICHT



BELTONEN



2 DRADEN



BEREIK
100 M

A - VEILIGHEIDSVOORSCHRIFTEN

1 - INLEIDING

Deze video-intercom combineert twee modules: een ontvangermonitor en een straatunit die gemakkelijk te installeren en te gebruiken is.

Belangrijkste kenmerken:

- Kleurenvideoscherm receptie: wanneer een bezoeker op de belknop op de straatplaat drukt, wordt het beeld onmiddellijk overgedragen naar het scherm en geeft een beltoon zijn/haar aanwezigheid aan.
- Bescherming in geval van kortsluiting
- Bescherming in geval van omgekeerde polariteit
- Automatische regeling van de blootstelling: de videocamera past zich automatisch aan de omgevingsverlichting.
- Biedt de mogelijkheid twee toegangen te beheren (slot en automatische bediening).
- Via het in de videocamera geïntegreerd infraroodzicht kunnen bezoekers worden geïdentificeerd zonder dat hiervoor extra verlichting nodig is.
- Opening van de deur en een bediening: door op de monitorknoppen te drukken, kunt u een elektrisch slot en een voltvrij contact voor de automatische bediening (niet meegeleverd) beheren.

BELANGRIJK: Voor het uitvoeren van de installatie dient u deze handleiding aandachtig te lezen. In geval van problemen staan de technici van onze Hotline voor nadere informatie voor u klaar.

OPGELET: fouten in de aansluiting kunnen schade aan het apparaat veroorzaken en de garantie nietig verklaren.

2 - ONDERHOUD EN REINIGING

Voordat u uw intercom installeert, is het belangrijk de volgende punten te controleren:

- Niet installeren bij extreme vochtigheid, temperatuur, corrosiegevaar of stof.
- De monitor niet direct blootstellen aan zonlicht, regen of een hoge vochtigheid.
- Het apparaat niet aansluiten op een stekkerblok of verlengkabel.
- Niet installeren in de buurt van andere elektronische apparaten, zoals een computer, televisietoestel of videorecorder.

- Het apparaat niet installeren vlak bij chemisch zure producten, ammoniak of een bron van giftige gasuitstoot.
- Niet reinigen met een schurend of bijtend product. Gebruik een met een zeepoplossing bevochtigde doek.
- Koppel het apparaat los als u het gedurende lange tijd niet gaat gebruiken.
- Het apparaat niet aansluiten op nationale telecommunicatie-installaties.

3 - RECYCLAGE



Dit logo betekent dat u geen apparaten die buiten gebruik zijn, mag wegwerpen bij het huishoudelijk afval.

De gevaarlijke stoffen die ze mogelijk kunnen bevatten, kunnen de gezondheid en het milieu schaden. Vraag uw distributeur om deze apparaten terug te nemen of maak gebruik van de middelen voor selectieve inzameling die door uw gemeente ter beschikking worden gesteld.



B - BESCHRIJVING VAN HET PRODUCT

1 - INHOUD VAN DE KIT

1 x1

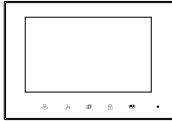

2 x1



3 x1

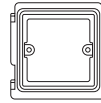

4 x5



5 x5



6 x3



7 x1



1	Monitor
2	Straatunit
3	Muursteen voor monitor
4	Bouten (2 voor de monitor, 3 voor de straatunit)

5	Bevestigingsschroeven (2 voor de monitor, 3 voor de straatunit)
6	Aansluiting straatunit naar monitor/elektrische slotplaat/automatische poort
7	Netwerkadapter

C - INSTALLATIE

De aanbevolen installatiehoogte bevindt zich op ca. 160 cm van de vloer voor de straatunit en 150 cm van de vloer voor de interne eenheid.

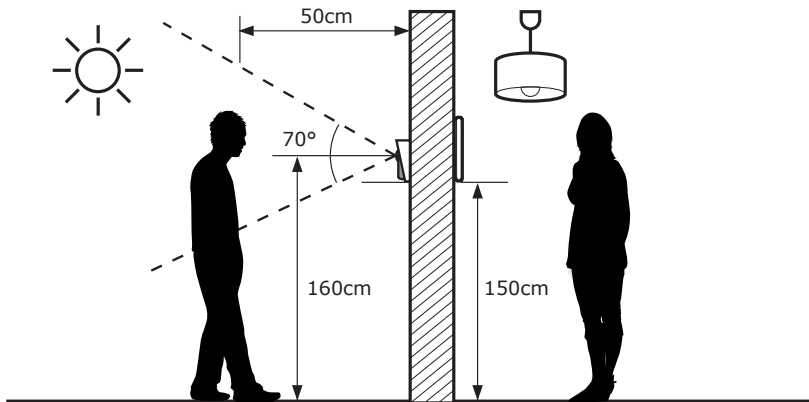

OPGELET: Om voor de hand liggende veiligheidsredenen, mogen de aansluitingen uitsluitend worden uitgevoerd nadat de elektrische voeding is uitgeschakeld.

1 - INSTALLATIE VAN DE STRAATUNIT

Bevestig de overkapping van de straatunit op uw zuil met behulp van voor de houder geschikte schroeven en pluggen (de geleverde schroeven en pluggen zijn geschikt voor muren van vol materiaal).

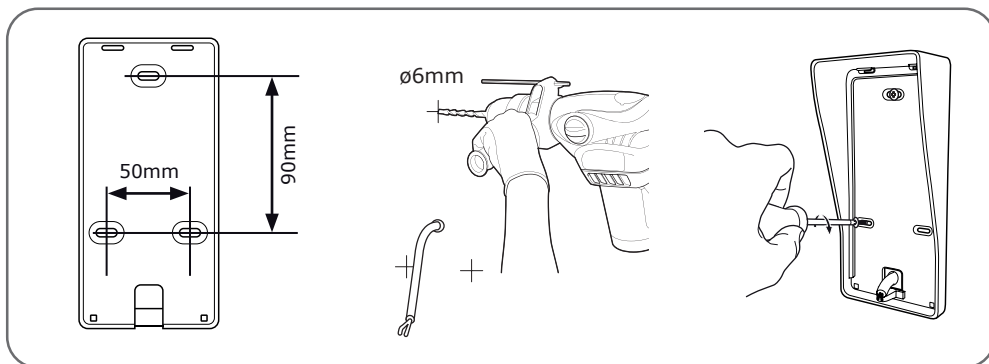

Na de aansluitingen van de straatunit uitgevoerd te hebben (zie paragraaf aansluitingen), plaatst u deze in de overkapping.

C - INSTALLATIE

Schroef de straatunit op de overkapping met behulp van de bijgeleverde schroef.

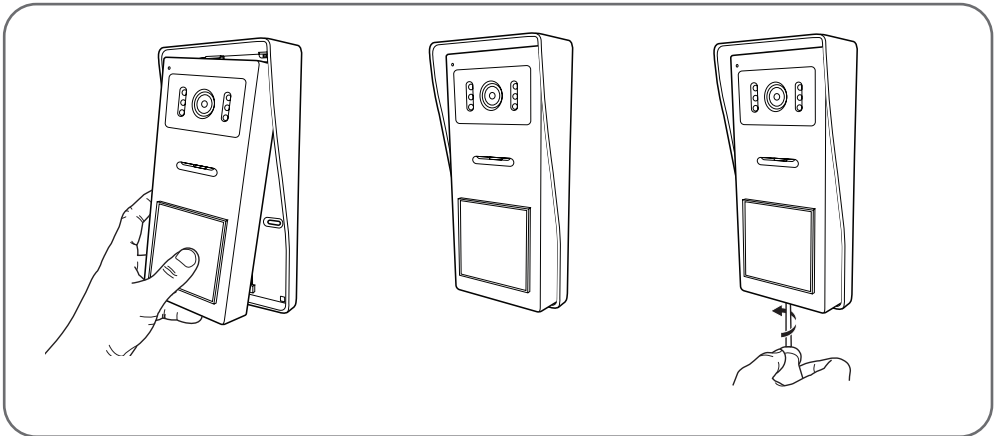

Breng het naambordje aan.

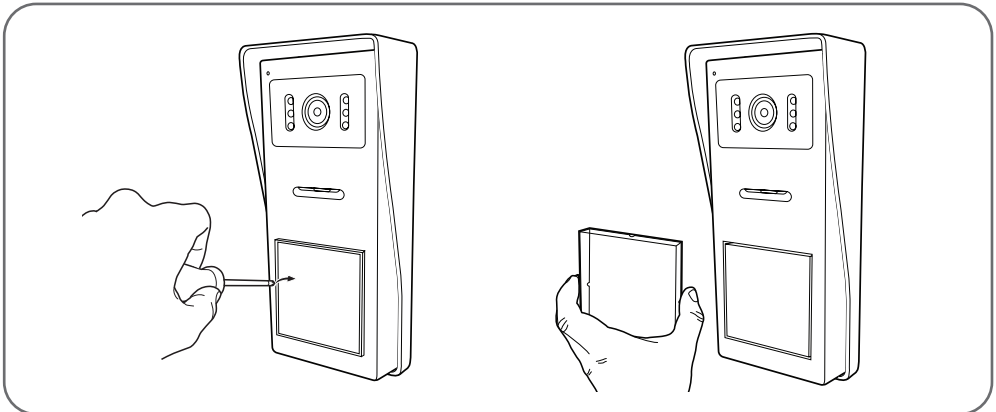

C - INSTALLATIE

2 - INSTALLATIE VAN HET SCHERM

Bevestig het met behulp van voor de steun geschikte schroeven en pluggen (de geleverde schroeven en pluggen zijn geschikt voor muren van vol materiaal).

Nadat u het scherm heeft aangesloten (zie hoofdstuk "aansluitingen"), bevestigt u het scherm op de steun.

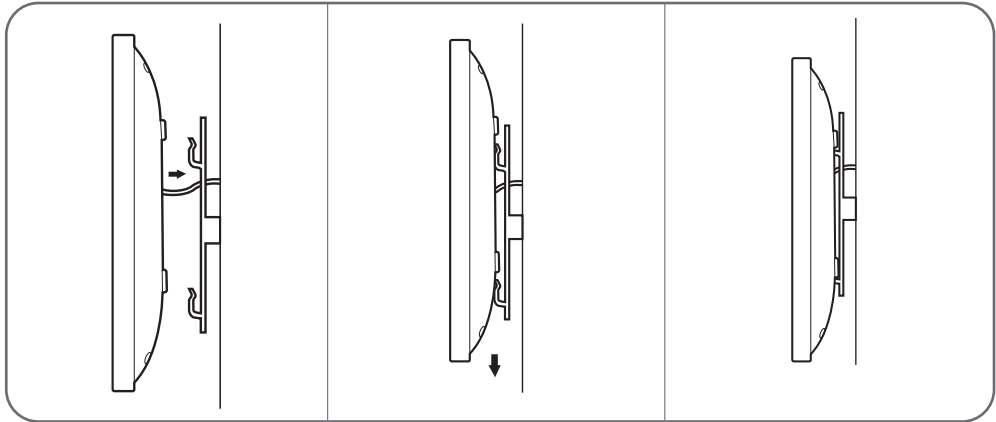
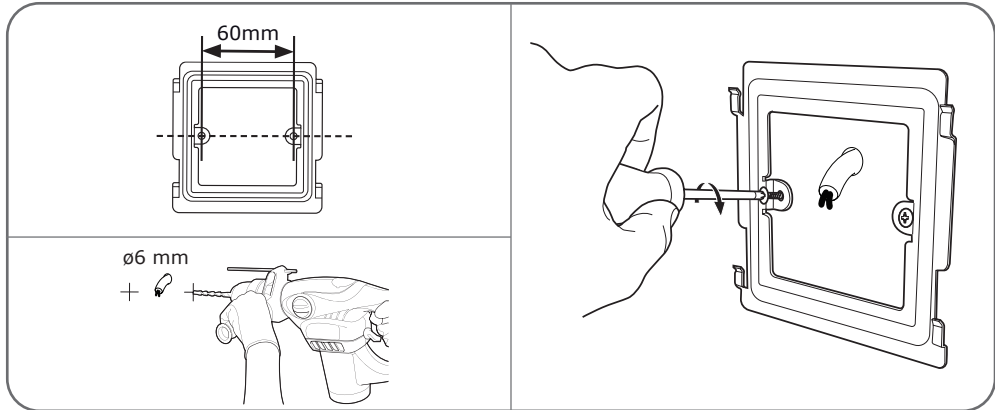

3 - DE AANSLUITINGEN

- Vermijd het gebruik van meerdere verdeelstekkers of aansluitingen op de verbindingdraad tussen de straatunit en het scherm
- Plaats de verbindingdraad tussen de straatunit en het scherm op meer dan 50 cm verwijderd van elke elektromagnetische storing (230V kabel, WiFi-apparaat, magnetron enz.)
- U kunt een elektrische slotplaat (niet meegeleverd) aansluiten en gebruiken met uw straatunit met of zonder mechanisch geheugen.

C - INSTALLATIE**Tussen het scherm en de straatunit (maximum 100 m)**

Voor een optimale beeld- en geluidskwaliteit, raden we u aan niet meer dan 100 m kabel te gebruiken tussen de intercom en de straatunit. Sluit de draden als volgt aan (een omwisseling van de draden bij aansluiting kan de straatunit beschadigen).

De te gebruiken kabeldoorsnede is afhankelijk van de lengte:

Lengte van de kabel	Te gebruiken doorsnede
Van 0 tot 50m	0,75mm ²
Van 50 tot 100 m	1,5mm ²

Tussen de straatunit en een elektrische slotplaat (niet meegeleverd)

Gebruik een slotplaat van maximaal 12V/1,1A met of zonder mechanisch geheugen.

Gebruik, voor de verbinding tussen de straatunit en de elektrische slotplaat, een kabel van het type:

Lengte van de kabel	Te gebruiken doorsnede
Van 0 tot 50m	0,75mm ²

Tussen de straatunit en de automatische poort (niet meegeleverd)

Te gebruiken doorsnede: 0,75mm² mini

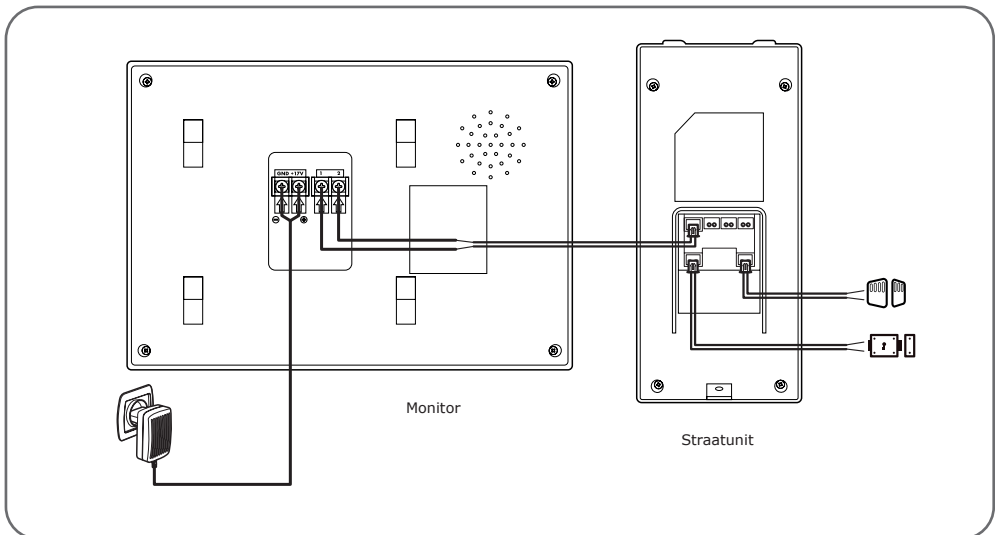
3.1 - AANSLUITING TUSSEN DE MONITOR EN DE STRAATUNIT

BELANGRIJK: sluit de uitgang van de poortbediening direct aan op het contact voor openen/sluiten van de automatische deur opener (bedrade besturingsingang van een automatische poort).

Uw video-intercom is uitgerust met de Polarity protect-functie: de aansluitrichting van de twee draden van de monitor, de elektrische slotplaat of de poort is niet belangrijk.



D - GEBRUIK

1 - IDENTIFICEREN VAN EN SPREKEN MET DE BEZOEKER

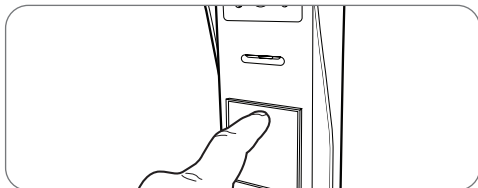
De bezoeker drukt op het naamplaatje van de straatunit:



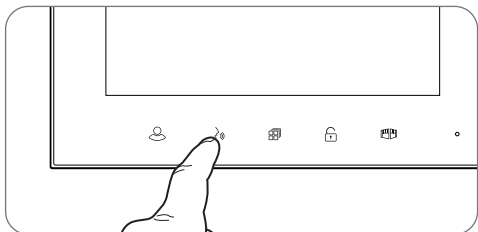

De deurbel weerklinkt via de luidspreker van de monitor die de videocamera van de straatunit activeert. Als de bezoeker zich binnen het veld van de camera bevindt, zal zijn beeld gedurende 30 seconden op de monitor verschijnen. Na het verstrijken van 30 seconden, gaat de monitor terug naar de stand-bystand.

Om met een bezoeker te praten, drukt u op de toets . Om de conversatie te beëindigen en de straatunit uit te schakelen, drukt u op de toets .



2 - ACTIVEREN VAN DE STRAATUNIT VANAF DE MONITOR

Om een bezoeker te identificeren zonder dat hij weet dat hij wordt geobserveerd of om gewoon buiten te kijken, drukt u op de toets : het beeld van de straatunit verschijnt vervolgens gedurende 60 seconden op het scherm.

Als u direct met de mensen buiten wilt communiceren, drukt u op de knop  zodra de videocamera buiten verschijnt.

Deze functie is vooral nuttig om de bezoeker te observeren, zelfs als deze nog niet op de belknop heeft gedrukt.

3 - OPENING VAN EEN ELEKTRISCH SLOT EN EEN AUTOMATISCHE BEDIENING

Als het apparaat is uitgerust met een elektrisch slot en/of een automatische bediening (zie paragraaf "aansluitingen"), drukt u op de toets  (voor het slot) of op  (voor de automatische bediening) om de bezoeker te laten binnenkomen.

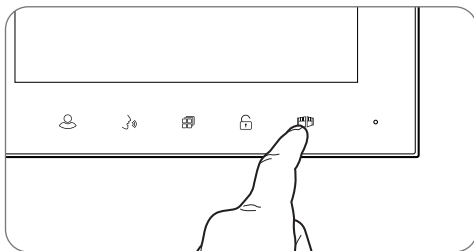
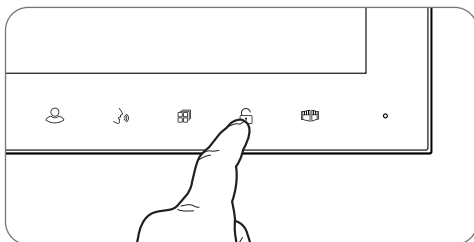

Opgelet, het is noodzakelijk dat het scherm aanstaat zodat de bedieningen met voltvrij contact en uitgang met spanning operationeel zijn. Als het scherm uitstaat, moet het aangezet worden met de knop .

D - GEBRUIK**4 - PARAMETERS OP DE MONITOR**

Druk, terwijl het scherm is ingeschakeld, op de toets



om het volgende scherm weer te geven:

Navigeer naar de submenu's door te drukken op de

toetsen .



- **BRT:**

Helderheid: druk op de toetsen en om het helderheidsniveau van het beeld te verlagen of te verhogen.

- **CON:**

Contrast: druk op de toetsen en om het contrastniveau van het beeld te verlagen of te verhogen.

- **COL:**

Kleur: druk op de toetsen en om het verzadigingsniveau van het beeld te verlagen of te verhogen.

- **CALL:**

Volume microfoon: druk op de toetsen en



om het volume van de microfoon te verhogen of te verlagen.

- **INCOME:**

Volume deurbel: druk op de toetsen en



om het volume van de deurbel te verlagen of te

verhogen.

- **RING:**

Selecteer de deurbel: druk op de toetsen en



om de gewenste deurbel te selecteren.

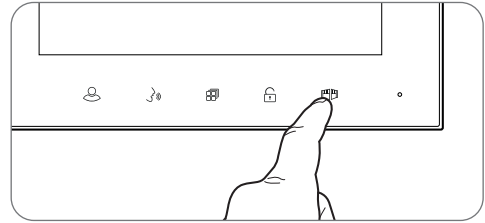

Als u eenmaal in het submenu RING bent, drukt u op de toets om dit menu te verlaten.

E - TECHNISCHE EN WETTELIJKE INFORMATIE

1 - TECHNISCHE KENMERKEN

MONITOR	
<i>Scherf</i>	Extra plat 7" kleuren-lcd
<i>Standaard video</i>	PAL/NTSC
<i>Resolutie</i>	800 x 480
<i>Voeding</i>	Met voedingsadapter 230 VAC 50 Hz/17 VDC 1,5 A meegeleverd
<i>Beveiliging</i>	Bescherming in geval van kortsluiting en in geval van omgekeerde polariteit
<i>Transmissiesysteem (audio en video)</i>	2 draden
<i>Ideaal bereik bedrijfstemperatuur</i>	-20 °C tot 50 °C
<i>Maximale vochtigheidsgraad</i>	85 %
<i>Aantal beltonen</i>	6
<i>Afmetingen</i>	209 x 144 x 22 cm

STRAATUNIT	
<i>Videocamera</i>	CMOS 420TVL
<i>Lens</i>	Horizontale gezichtshoek 100°
<i>Voeding</i>	13 VDC geleverd door de monitor
<i>Max. verbruik</i>	200 mA
<i>Helderheid</i>	min 0 lux
<i>Nachtzicht</i>	Van 0,5 tot 1 m
<i>Afmetingen</i>	157 x 72 x 27 mm
<i>Beschermingsgraad</i>	IP44

2 - GARANTIE

- Dit product valt 3 jaar onder garantie, onderdelen en werkuren, vanaf de aankoopdatum. U moet het aankoopbewijs gedurende de hele garantieperiode bewaren.
- De garantie is niet van toepassing op schade veroorzaakt door nalatigheid, schokken of ongevallen.
- Elke interventie aan het apparaat annuleert de garantie.
- De kabel van de netwerkadapter niet doorsnijden of verlengen, omdat de garantie hierdoor geannuleerd kan worden.

3 - HULP EN TIPS

- Ondanks de zorg die wij besteed hebben aan het ontwerp van onze producten en het

schrijven van deze handleiding, en u ervaart toch nog problemen tijdens de installatie van uw product of u heeft vragen, dan raden wij u aan contact op te nemen met onze specialisten die altijd met raad en daad klaarstaan.

- Bij werkingsproblemen tijdens de installatie of na enkele dagen gebruik, moet u voor installatie contact met ons opnemen zodat een van onze technici de oorzaak van het probleem kan zoeken aangezien dit waarschijnlijk uit een foute instelling of een niet conforme installatie voortkomt.

Neem contact op met de technisch medewerkers van onze klantenservice op:

+352 26302353

Van maandag tot vrijdag van 9 tot 12 uur en van 13 tot 17 uur.

DE

Farbvideo-Gegensprechanlage 7" 2-Draht

Art.-Nr. 340100



3 Jahre GARANTIE



MONITOR 7"



NACHT-
SICHT



KLINGELTÖNE



2-DRAHT



REICHWEITE
100 M

A - SICHERHEITSANWEISUNGEN

1 - EINLEITUNG

Diese Video-Gegensprechanlage besteht aus zwei Modulen : ein Empfänger-Monitor und eine benutzerfreundliche straßenseitige Türsprechanlage, die leicht zu montieren ist.

Hauptmerkmale:

- Farbvideo-Empfang: Wenn ein Besucher die Ruftaste der Türsprechanlage drückt, erscheint sofort sein Bild auf dem Display und es ertönt ein Klingelton.
- Schutz bei Kurzschluss
- Schutz bei Polungsumkehrung
- Automatische Belichtungseinstellung: Die Videokamera passt sich automatisch den Lichtverhältnissen in der Umgebung an.
- Ermöglicht die Steuerung von zwei Zugängen (automatischer Türöffner und Steuerung des Torantriebs).
- Durch die in die Videokamera integrierte Infrarot-Funktion können Besucher ohne zusätzliche Lichtquelle identifiziert werden.
- Öffnen der Tür und eines Torantriebs: Mit den Tasten des Monitors können Sie einen elektrischen Türöffner und einen potenzialfreien Kontakt für den automatischen Torantrieb (nicht im Lieferumfang) bedienen.

WICHTIG: Diese Anleitung muss vor der Installation aufmerksam gelesen werden. Bei Problemen stehen Ihnen die Techniker unserer Hotline jederzeit zur Verfügung.

ACHTUNG: Anschlussfehler können zu Geräteschäden und zum Erlöschen der Garantie führen.

2 - INSTANDHALTUNG UND REINIGUNG

Überprüfen Sie vor der Installation Ihrer Gegensprechanlage die folgenden Punkte:

- Nicht installieren bei Gefahr von sehr starker Feuchtigkeit, sehr hohen Temperaturen oder sehr starker Staubbildung.
- Setzen Sie den Monitor nicht direkt der Sonne, Regen oder starker Feuchtigkeit aus.
- Das Gerät nicht an eine Mehrfachsteckdose oder ein Verlängerungskabel anschließen.
- Nicht in der Nähe anderer elektronischer Geräte wie z. B. Computer, Fernseher oder Videorekorder, installieren.
- Installieren Sie das Gerät nicht in der Nähe

von chemischen Produkten wie Säuren und Ammoniak oder einer Emissionsquelle für giftige Gase.

- Nicht mit scheuernden oder ätzenden Produkten reinigen. Ein mit Seifenwasser leicht angefeuchtetes Tuch verwenden.
- Das Gerät vom Stromnetz trennen, wenn es längere Zeit nicht in Gebrauch sein wird.
- Das Gerät nicht an die öffentlichen Telekom-Leitungen anschließen.

3 - RECYCLING



Dieses Logo bedeutet, dass Altgeräte nicht mit dem Hausmüll entsorgt werden dürfen.

Sie enthalten möglicherweise gefährliche Substanzen, die der Gesundheit und der Umwelt schaden können. Geben Sie Altgeräte bei der Verkaufsstelle oder über die getrennte Abfuhr Ihrer Gemeinde zurück.



B - PRODUKTBESCHREIBUNG

1 - INHALT DES SETS

1 x 1

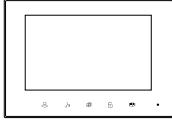

2 x 1



3 x 1

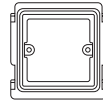

4 x 5



5 x 5



6 x 3



7 x 1



1	Monitor
2	Türsprechanlage
3	Wandhalterung für Monitor
4	Dübel (2 für den Monitor, 3 für die Türsprechanlage)

5	Befestigungsschrauben (2 für den Monitor, 3 für die Türsprechanlage)
6	Anschlussstecker der Türsprechanlage zu Monitor/elektrischem Türöffner/Torantrieb
7	Netzadapter

C - MONTAGE

Die empfohlene Montagehöhe beträgt für die Türsprechanlage ca. 160 cm ab dem Boden und 150 cm für die Gegensprechanlage in der Wohnung.

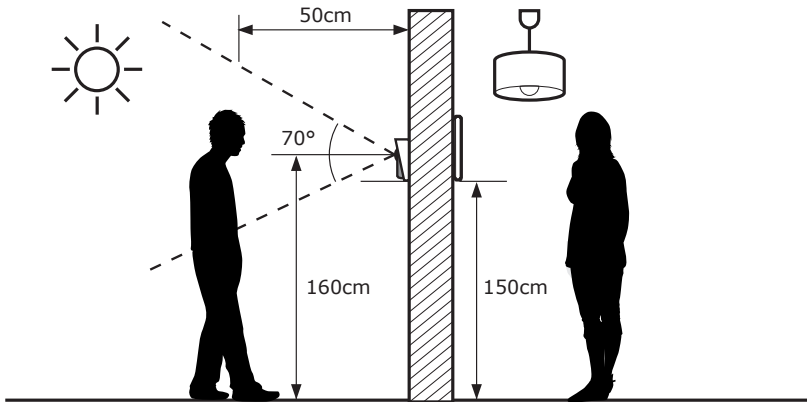

ACHTUNG: Aus offenkundigen Sicherheitsgründen dürfen Verkabelungen nur bei abgeschalteter Stromversorgung erfolgen.

1 - INSTALLATION DER TÜRSPRECHANLAGE

Den Regenschutz der Türsprechanlage mittels geeigneter Schrauben und Dübel auf Ihrem Pfeiler befestigen (die mitgelieferten Schrauben und Dübel sind für massive Wände geeignet).

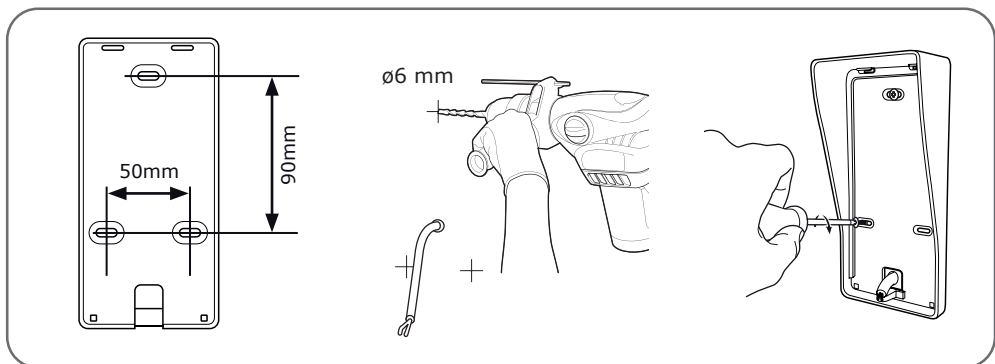

Nach der Verkabelung der Türsprechanlage (siehe Abschnitt Anschlüsse), diese im Regenschutz einsetzen.

C - MONTAGE

Dann die Türsprechanlage mittels der mitgelieferten Schrauben am Regenschutz festschrauben.

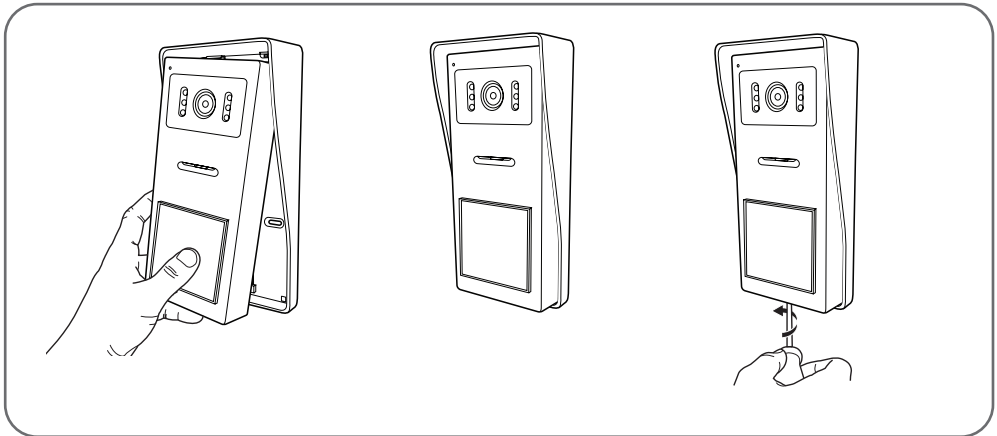

Das Namensschild anbringen.

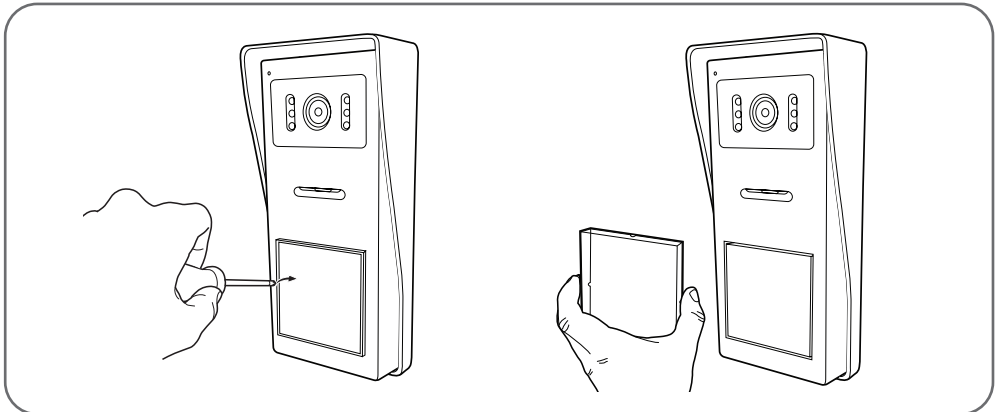

C - MONTAGE

2 - MONTAGE DES MONITORS

Die Wandhalterung mittels geeigneter Schrauben und Dübel an der Wand befestigen (die mitgelieferten Schrauben und Dübel sind für massive Wände geeignet).

Nach der Verkabelung des Monitors (siehe Abschnitt „Anschlüsse“) den Monitor an seiner Halterung befestigen.

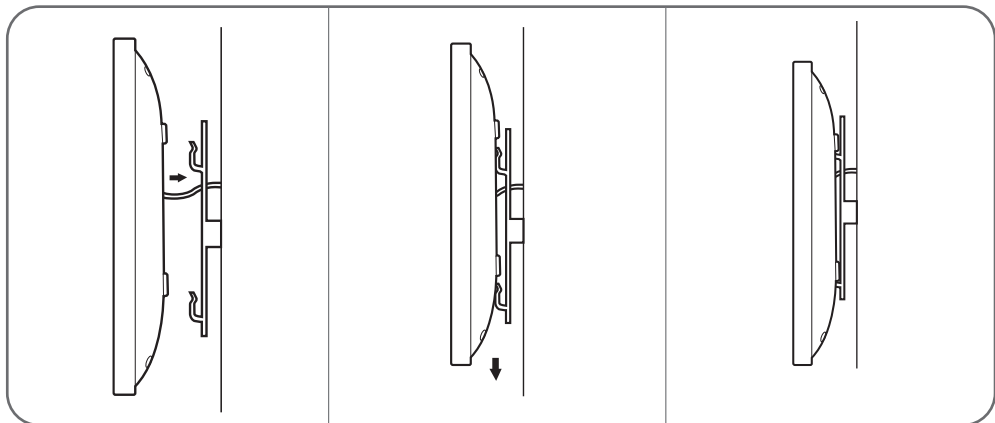
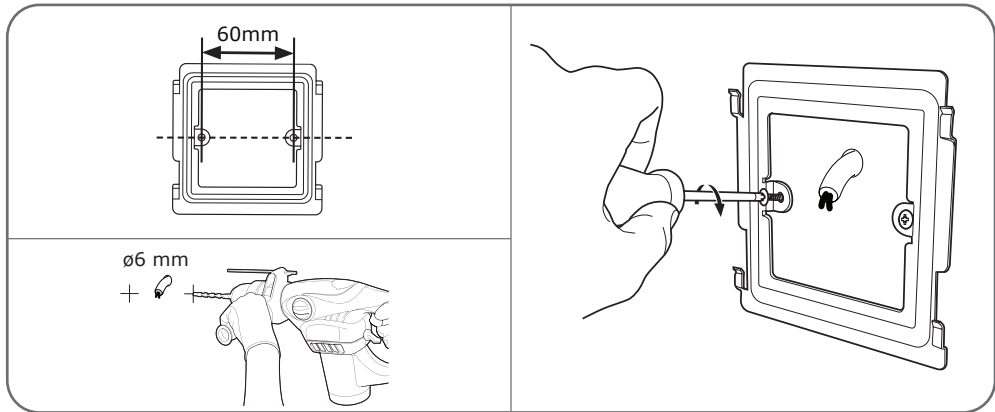

3 - DIE ANSCHLÜSSE

- Vermeiden Sie es, im Verlauf des Verbindungskabels zwischen Türsprechanlage und Monitor mehrere Lüsterklemmen oder Verlängerungskabel hintereinander zu schalten
- Halten Sie aus einem Bereich von 50 cm um das Verbindungskabel zwischen Türsprechanlage und Monitor alle elektromagnetischen Störquellen (230V Kabel, WLAN-Geräte, Mikrowellen-Geräte, usw.) fern.
- Sie können mit der Türsprechanlage einen elektrischen Türöffner (nicht im Lieferumfang enthalten) verbinden und benutzen, mit oder ohne mechanischem Gedächtnis.

C - MONTAGE**Zwischen dem Monitor und der Türsprechanlage (max. 100 m)**

Um eine gute Audio- und Video-Qualität zu gewährleisten, sollte die Kabellänge zwischen der Gegensprechanlage und der Türsprechanlage nicht mehr als 100 m betragen. Die Drähte wie folgt verbinden (eine falsche Verkabelung kann die Türsprechanlage beschädigen).

Der Durchmesser des zu verwendenden Kabels hängt von seiner Länge ab:

Länge des Kabels	Zu verwendender Kabeldurchmesser
0 bis 50m	0,75 mm ²
Von 50 m bis 100 m	1,5 mm ²

Zwischen der Türsprechanlage und einem elektrischen Türöffner (nicht mitgeliefert)

Einen Türöffner 12V/1,1A max. mit oder ohne mechanischen Speicher verwenden.

Für die Verbindung zwischen der Türsprechanlage und dem Türöffner, Kabel von folgendem Typ verwenden:

Länge des Kabels	Zu verwendender Kabeldurchmesser
0 bis 50m	0,75 mm ²

Zwischen der Türsprechanlage und einem motorisierten Tor (nicht mitgeliefert)

Zu verwendender Durchmesser: Mindestens 0,75 mm²

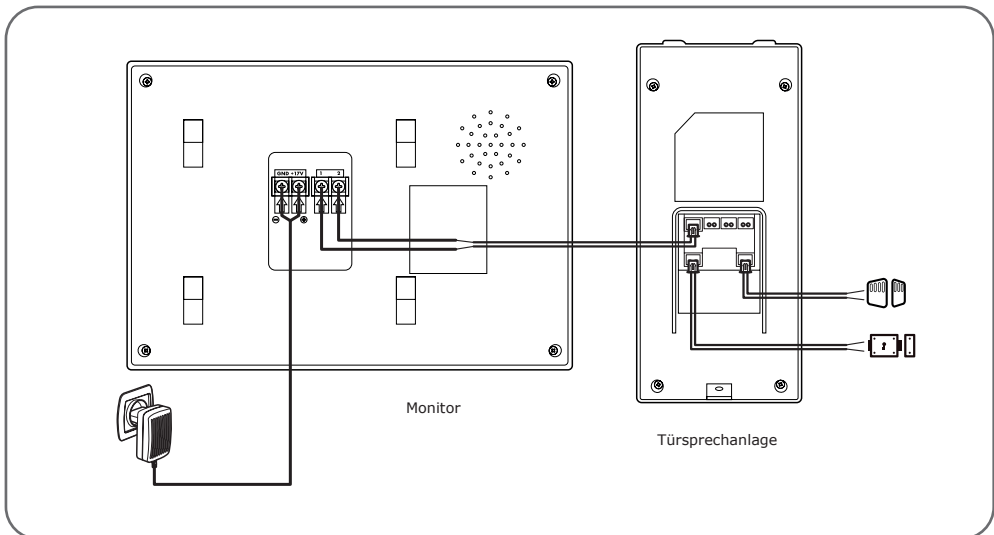
3.1 - ANSCHLUSS ZWISCHEN MONITOR UND STRASSESEITIGER TÜRSPRECHANLAGE

WICHTIG: Verbinden Sie den Ausgang der Torsteuerung direkt mit dem Öffner-/Schließkontakt der automatischen Steuerung (drahtgebundener Steuereingang eines Torantriebs).

Ihre Video-Türsprechanlage ist mit der Polarity-Protect-Funktion ausgestattet: Die Anschlussrichtung der beiden Drähte des Monitors, des elektrischen Türöffners oder des Tors spielt daher keine Rolle.

D - VERWENDUNG

1 - DEN BESUCHER IDENTIFIZIEREN UND MIT IHM SPRECHEN

Der Besucher drückt auf das Namensschild der Türsprechanlage:



Die Klingel wird über den Lautsprecher des Monitors ausgelöst, der die Videokamera der Türsprechanlage aktiviert. Befindet sich der Besucher im Aufnahmefeld der Kamera, ist sein Bild 30 Sekunden lang auf dem Monitor zu sehen. Nach 30 Sekunden schaltet der Monitor wieder in den Standby-Modus.

Drücken Sie die Taste , um mit dem Besucher zu sprechen. Zur Beendigung des Gesprächs und Deaktivierung der Türsprechanlage drücken Sie die Taste .

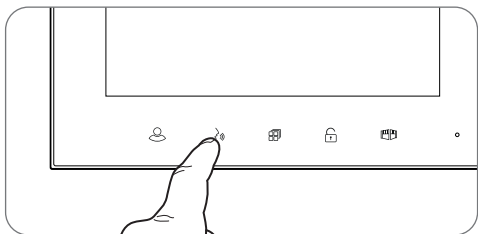



2 - AKTIVIERUNG DER TÜRSPRECHANLAGE AB DEM MONITOR

Um einen Besucher zu identifizieren, ohne dass dieser merkt, dass er beobachtet wird, oder um nach draußen zu schauen, drücken Sie die Taste : Auf dem Display erscheint 60 s lang das von Türsprechanlage aufgenommene Bild.

Um direkt mit dem Außenbereich zu kommunizieren, drücken Sie die Taste , sobald das türseitige Videobild auf dem Display erscheint.

Diese besonders nützliche Funktion ermöglicht auch dann eine Beobachtung des Besuchers, wenn dieser nicht geklingelt hat.

3 - BETÄTIGUNG EINES ELEKTRISCHEN TÜRÖFFNERS UND EINES TORANTRIEBS

Wenn das Gerät mit einem elektrischen Türöffner und/oder der Steuerung eines automatischen Torantriebs ausgestattet ist (siehe Paragraph „ANSCHLUSS“), drücken Sie die Taste  (für das Türschloss) oder  (für den automatischen Torantrieb), um den Besucher einzulassen.

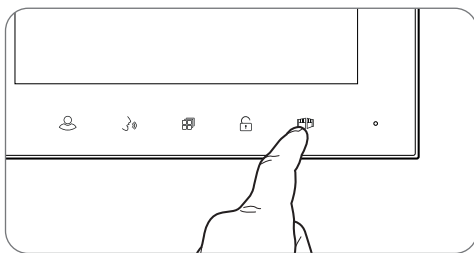
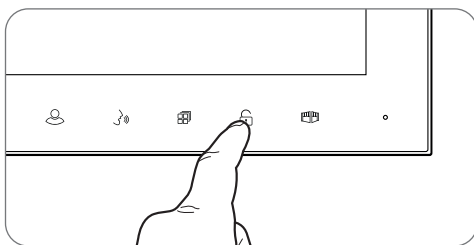

Achtung: Der Bildschirm muss eingeschaltet sein, damit die Befehle potenzialfreier Kontakt und spannungsführender Ausgang ausführbar sind. Ist der Bildschirm ausgeschaltet, ist er mithilfe der Taste  einzuschalten.



D - VERWENDUNG



4 - PARAMETER AUF DEM MONITOR



Drücken Sie bei eingeschaltetem Display die Taste , um das folgende Fenster aufzurufen:



Navigieren Sie durch die Untermenüs, indem Sie die Tasten  betätigen.



• **BRT:**
Helligkeit: Drücken Sie die Tasten  und , um die Helligkeit des Bildes zu steigern oder zu reduzieren.

• **CON:**
Kontrast: Drücken Sie die Tasten  und , um den Kontrast des Bildes zu steigern oder zu reduzieren.

• **COL:**
Farbe: Drücken Sie die Tasten  und , um die Sättigung des Bildes zu steigern oder zu reduzieren.

• **CALL:**
Lautstärke Mikrophon: Drücken Sie die Tasten  und , um die Lautstärke des Mikrofons zu steigern oder zu reduzieren.

• **INCOME:**
Lautstärke Türklingel: Drücken Sie die Tasten  und , um den Klingelton lauter oder leiser zu stellen.

• **RING:**
Auswahl des Klingeltons: Drücken Sie zur Auswahl des gewünschten Klingeltons die Tasten  und .

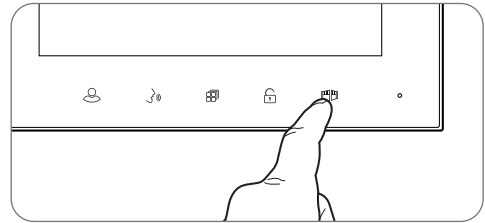

Befinden Sie sich im Untermenü RING, betätigen Sie die Taste , um es zu verlassen.

E - TECHNISCHE UND GESETZLICHE INFORMATIONEN

1 - TECHNISCHE MERKMALE

MONITOR	
Bildschirm	Farbe 7 Zoll LCD extraflach
Videostandard	PAL/NTSC
Auflösung	800 x 480
Stromversorgung	Mit dem mitgelieferten Netzadapter 230 V AC, 50 Hz/17 V DC 1,5 A
Schutz	Schutz bei Kurzschluss und Umkehrung der Polung
Übertragungssystem (Audio und Video)	2-Draht
Idealer Betriebstemperaturbereich	-20 °C bis 50 °C
Max. Luftfeuchtigkeit	85 %
Anzahl an Klingeltönen	6
Abmessungen	209 x 144 x 22 cm

TÜRSPRECHANLAGE	
Videokamera.	CMOS 420TVL
Objektiv	Blickwinkel horizontal 100°
Stromversorgung	13 V DC vom Monitor geliefert
Max. Verbrauch	200 mA
Helligkeit	min. 0 Lux
Nachtsicht	0,5 bis 1 m
Abmessungen	157 x 72 x 27 mm
Schutzart	IP44

2 - GARANTIE

- Für dieses Gerät gilt ab Kaufdatum eine 3-jährige Garantie auf Teile und Reparatur. Es zwingend notwendig, dass Sie während der gesamten Garantiedauer einen Kaufnachweis aufbewahren.
- Die Garantie gilt nicht für Schäden, die durch Nachlässigkeit, Stöße oder Unfälle verursacht wurden.
- Jeglicher Eingriff am Gerät führt zum Erlöschen der Garantie.
- Das Netzadapterkabel darf nicht abgeschnitten oder verlängert werden. Anderenfalls erlischt die Garantie.

3 - HILFE UND SUPPORT

- Trotz aller Sorgfalt, die wir bei der Konzeption unserer Produkte und der Verfassung dieser

Bedienungsanleitung aufgewendet haben, kann es sein, dass Sie während der Installation Ihres Geräts auf Schwierigkeiten oder Fragen stoßen. In diesem Fall raten wir Ihnen dringend, unsere Spezialisten zu kontaktieren, die Sie gerne beraten.

- Sollten bei der Installation oder der Verwendung in den Tagen danach Funktionsstörungen auftreten, ist es zwingend erforderlich, dass Sie uns kontaktieren, während Sie das Gerät vor sich haben. So können unsere Techniker die Ursache des Problems diagnostizieren, denn dieses ist wahrscheinlich auf eine falsche Einstellung oder eine nicht ordnungsgemäße Installation zurückzuführen.

Sie erreichen unsere Kundendienst-Techniker unter:

+352 26302353

Von Montag bis Freitag von 9:00 bis 12:00 und von 13:00 bis 17:00.

ES

Videoportero en color de 7"

2 cables

ref. 340100



GARANTÍA de 3 años



PANTALLA DE 7"



VISIÓN
NOCTURNA



TIMBRES



2 CABLES



ALCANCE
100 M

A - NORMAS DE SEGURIDAD

1 - INTRODUCCIÓN

Este videoportero asocia dos módulos: un monitor receptor y una placa externa sencilla de instalar y usar.

Características principales:

- Recepción de vídeo en color: cuando un visitante pulsa la tecla de llamada de la placa externa, se transmite inmediatamente la imagen a la pantalla y un timbre avisa de su presencia.
- Protección en caso de cortocircuito
- Protección en caso de inversión de polaridad
- Ajuste automático de la exposición: la cámara de vídeo se ajusta automáticamente a las condiciones de iluminación ambiente.
- Permite controlar dos accesos (cerradura y accionamiento automático).
- La visión por infrarrojos integrada en la cámara de vídeo permite identificar a los visitantes sin necesidad de iluminación adicional.
- Apertura de la puerta y de un accionamiento: pulsando las teclas del monitor, puede controlar una cerradura eléctrica y un contacto seco para el accionamiento automático (no suministrado).

IMPORTANTE: Debe leer estas instrucciones con atención antes de la instalación. En caso de problema, los técnicos de nuestra línea de atención técnica se encuentran a su disposición para cualquier información.

ATENCIÓN: cualquier error de conexión puede causar daños al aparato y anular la garantía.

2 - MANTENIMIENTO Y LIMPIEZA

Antes de instalar el interfono, es importante que compruebe los puntos siguientes:

- No instalar en caso de condiciones extremas de humedad, de temperatura, de riesgo de corrosión o de polvo.
- No exponer directamente el monitor a la luz del sol, a la lluvia o a una fuerte humedad.
- No conectar el aparato a un ladrón o a un alargador.
- No instalar cerca de otros aparatos eléctricos, como un ordenador, una televisión o una grabadora de vídeo.

- No instalar cerca de productos químicos ácidos, amoníaco o una fuente que emita gases tóxicos.
- No limpiar con un producto abrasivo o corrosivo. Usar un trapo ligeramente húmedo con agua jabonosa.
- Desconectar el aparato si no se usa durante un largo periodo de tiempo.
- No conectar el aparato a las instalaciones de telecomunicación.

3 - RECICLAJE



Este logotipo significa que no se deben tirar aparatos inservibles con los residuos domésticos.

Las posibles sustancias peligrosas contenidas en el aparato pueden perjudicar a la salud o al medio ambiente.

Entregue estos aparatos a su distribuidor o utilice los servicios municipales de recogida selectiva.



B - DESCRIPCIÓN DEL PRODUCTO

1 - CONTENIDO DEL KIT

1 x 1

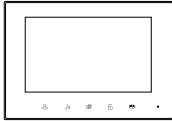

2 x 1



3 x 1

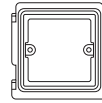

4 x 5



5 x 5



6 x 3



7 x 1



1	Monitor
2	Placa externa
3	Soporte de pared para el monitor
4	Tacos (2 para el monitor, 3 para la placa externa)

5	Tornillos de fijación (2 para el monitor, 3 para la placa externa)
6	Conector de placa externa al monitor/ cerradero eléctrico/motorización de cancela
7	Adaptador de red

C - INSTALACIÓN

La altura de instalación recomendada es de aproximadamente a 160 cm del suelo para la placa externa y 150 cm para la unidad interna.

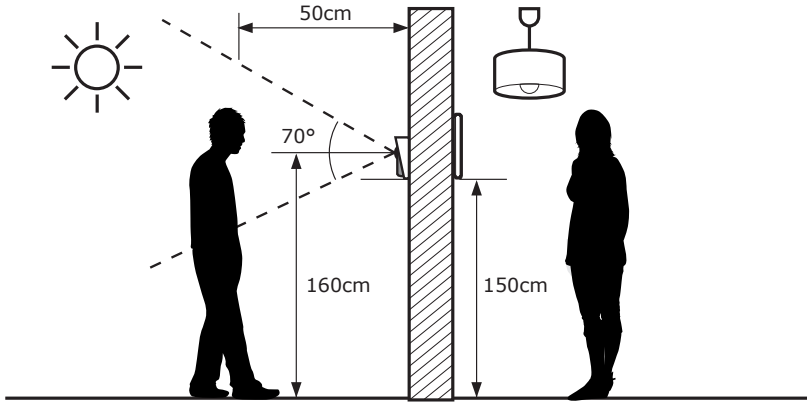

ATENCIÓN: Por motivos evidentes de seguridad, las conexiones solo se pueden realizar después de haber cortado la alimentación eléctrica.

1 - INSTALACIÓN DE LA PLACA EXTERNA

Fije la caja de la placa externa en el pilar con los tornillos y tacos adaptados al soporte (los tornillos y tacos suministrados son adecuados para paredes macizas).

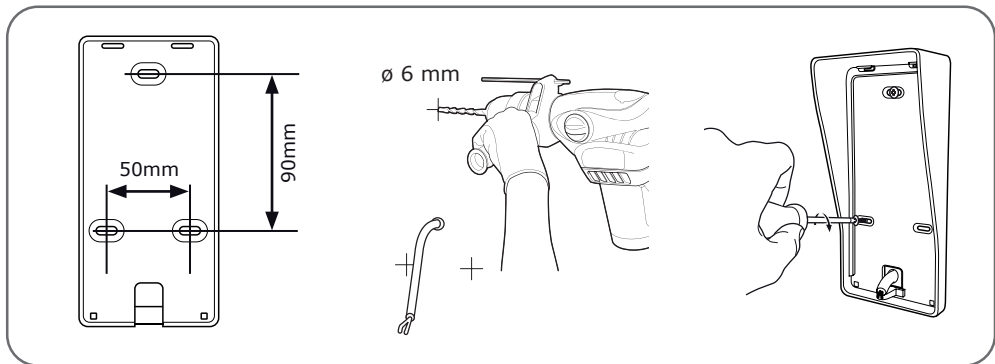

Después de haber realizado las conexiones de la placa externa (consulte el párrafo «conexiones»), colóquela en la caja.

C - INSTALACIÓN

A continuación, atornille la placa externa a la caja con el tornillo suministrado.

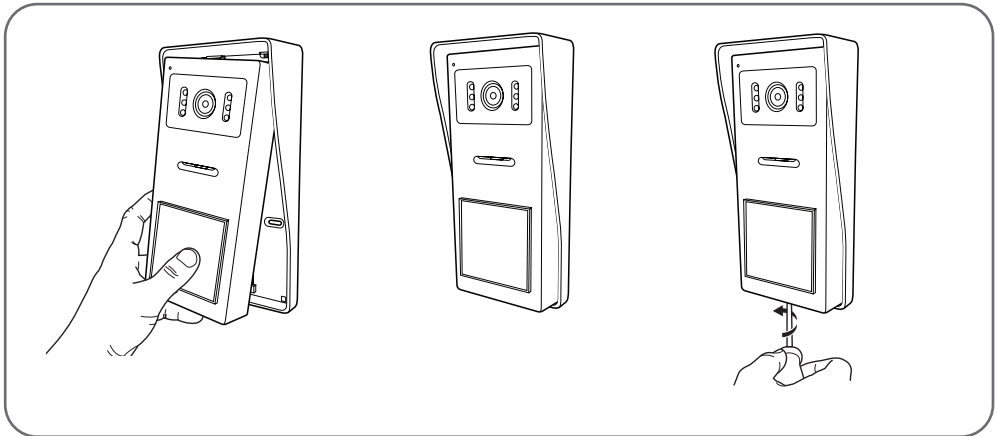

Coloque la etiqueta con el nombre.

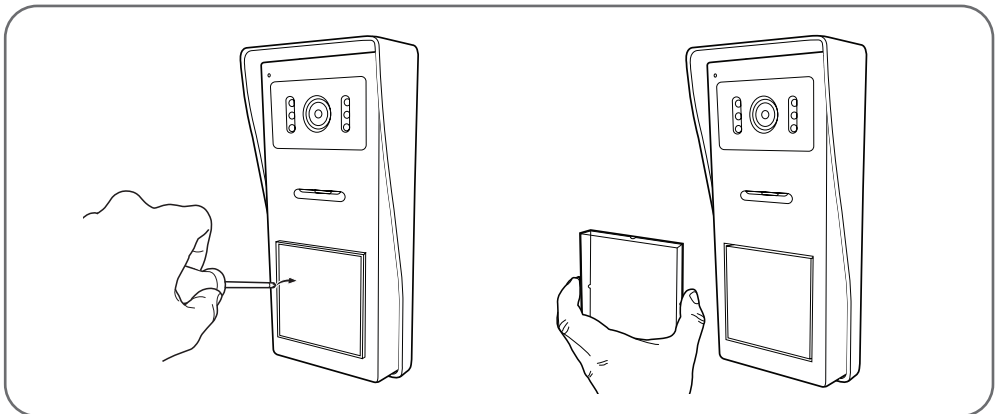

C - INSTALACIÓN

2 - INSTALACIÓN DEL MONITOR

Fije el soporte mural en la pared con los tornillos y tacos adaptados al soporte (los tornillos y tacos suministrados son adecuados para las paredes macizas).

Después de haber realizado las conexiones del monitor (consulte el párrafo «conexiones»), fije el monitor en su soporte.

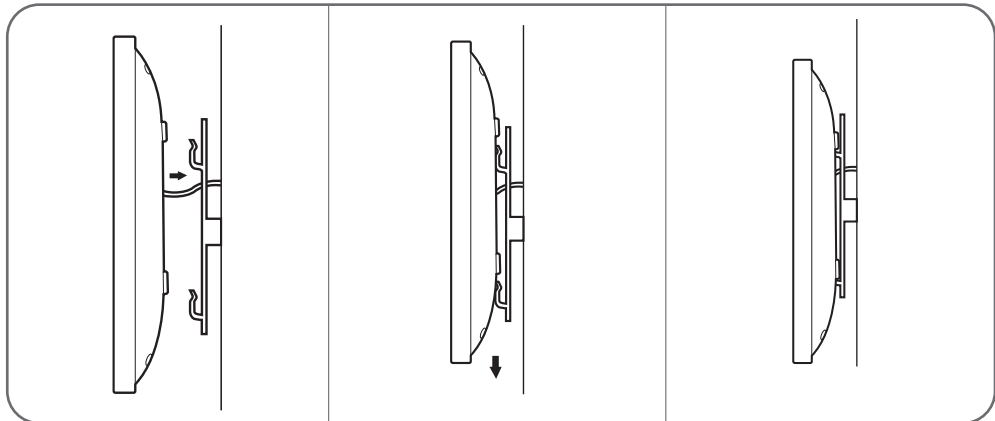
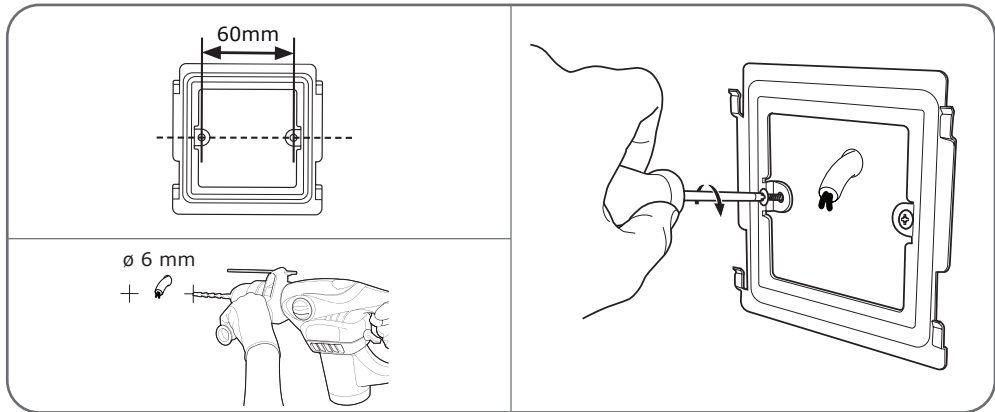

3 - LAS CONEXIONES

- No multiplique las regletas de bornes o los empalmes en el cable de conexión entre la placa externa y el monitor
- Aleje el cable de conexión entre la placa externa y el monitor de más de 50 cm de cualquier interferencia electromagnética (cable 230 V, aparato WiFi, microondas, etc.).
- Puede conectar y usar un cerradero eléctrico (no suministrado) con la placa externa, con o sin memoria mecánica.

C - INSTALACIÓN

Entre el monitor y la placa externa (100 m como máximo)

Para asegurar una buena calidad de sonido y de imagen, se recomienda no usar más de 100 m de cable entre el videoportero y la placa externa. Conecte los cables correctamente, tal como se indica a continuación (una inversión de la conexión puede dañar la placa externa).

La sección del cable que debe usar depende de su longitud:

Longitud del cable	Sección que debe usar
De 0 a 50 m	0,75 mm ²
De 50 m a 100 m	1,5 mm ²

Entre la placa externa y un cerradero eléctrico (no suministrado)

Use un cerradero de 12 V / 1,1A como máximo con o sin memoria mecánica.

Para la conexión entre la placa externa y el cerradero, use cable de tipo:

Longitud del cable	Sección que debe usar
De 0 a 50 m	0,75 mm ²

Entre la placa externa y una motorización de cancela (no suministrada)

Sección que debe usar: 0,75 mm² mín.

3.1 - CONEXIÓN ENTRE EL MONITOR Y LA PLACA EXTERNA

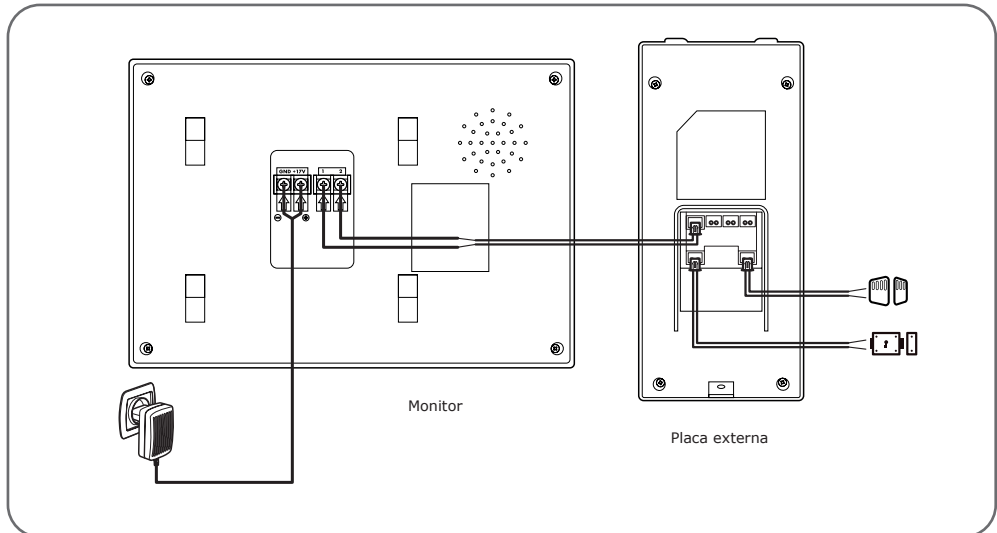

IMPORTANTE: conecte la salida de control de la cancela directamente al contacto de apertura/cierre del accionamiento automático (entrada de control por cable de una motorización de cancela).

El videoportero dispone de la función Polarity Protect: el sentido de conexión de los dos cables del monitor, del cerradero eléctrico o de la cancela no tiene importancia.

D - USO

1 - IDENTIFICAR AL VISITANTE Y HABLAR CON ÉL

El visitante pulsa el portanombres de la placa externa:

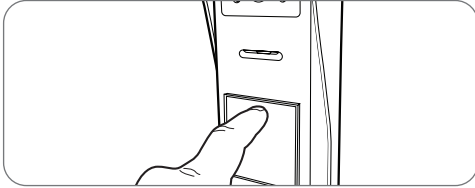

el timbre suena a través de un altavoz del monitor que activa la cámara de video de la placa externa. Si el visitante se encuentra en el campo de visión de la cámara, su imagen aparecerá en el monitor durante 30 segundos. Después de los 30 segundos, el monitor volverá al modo de suspensión.

Para hablar con el visitante, pulse la tecla . Para finalizar la conversación y desactivar la placa externa, pulse la tecla .

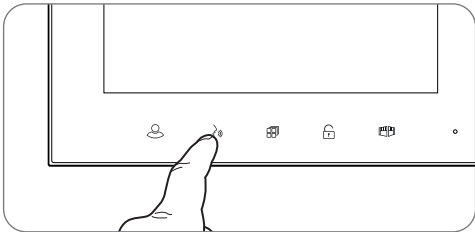

2 - ACTIVAR LA PLACA EXTERNA DESDE EL MONITOR

Para identificar a un visitante sin que sepa que se le observa o simplemente para mirar fuera, pulse la tecla : la imagen de la placa externa aparece entonces en la pantalla durante 60 segundos.

Si desea comunicarse directamente con el exterior, pulse la tecla una vez que se visualiza la cámara de video externa.

Esta función especialmente útil le permite observar al visitante, incluso si no ha llamado.

3 - APERTURA DE UNA CERRADURA ELÉCTRICA Y DE UN ACCIONAMIENTO AUTOMÁTICO

Si el aparato está equipado con una cerradura eléctrica y/o un accionamiento automático (consulte el párrafo «Conexión»), pulse la tecla (para la cerradura) o (para el accionamiento automático) para dejar entrar al visitante.

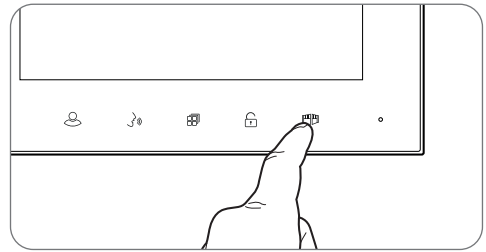
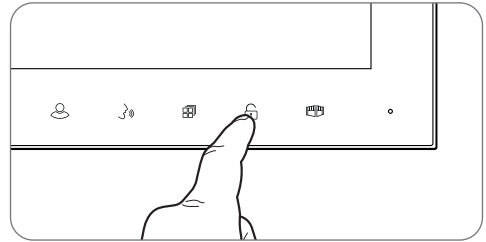

Atención: es necesario que la pantalla se encienda para que los controles con contacto seco y salida alimentada funcionen. Si la pantalla está apagada, se la debe encender con el botón .

D - USO



4 - PARÁMETROS EN EL MONITOR

Mientras la pantalla está encendida, pulse la tecla  para visualizar la pantalla siguiente:

Navegue por los submenús pulsando las teclas .



• BRT:

Luminosidad: pulse las teclas  y  para reducir o aumentar el nivel de luminosidad de la imagen.



• CON:

Contraste: pulse las teclas  y  para reducir o aumentar el nivel de contraste de la imagen.

• COL:

Color: pulse las teclas  y  para reducir o aumentar el nivel de saturación de la imagen.



• CALL:

Volumen del micrófono: pulse las teclas  y  para aumentar o reducir el volumen del micrófono.

• INCOME:

Volumen del timbre: pulse las teclas  y  para reducir o aumentar el volumen del timbre.

• RING:

Seleccionar el timbre: pulse las teclas  y  para seleccionar el timbre deseado.

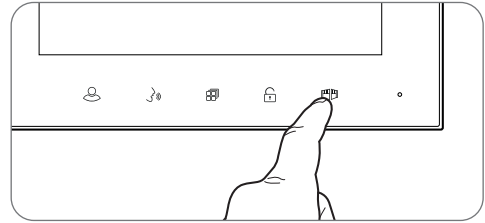

Una vez en el submenú RING, pulse la tecla  para salir.

E - INFORMACIÓN TÉCNICA Y LEGAL

1 - CARACTERÍSTICAS TÉCNICAS

MONITOR	
<i>Pantalla</i>	Color de 7 pulgadas LCD extraplano
<i>Estándar del vídeo</i>	PAL/NTSC
<i>Resolución</i>	800 x 480
<i>Alimentación</i>	Con adaptador de red de 230 V ca 50 Hz/17 V cc 1,5 A incluido
<i>Protección</i>	Protección en caso de cortocircuito y en caso de inversión de la polaridad
<i>Sistema de transmisión (audio y vídeo)</i>	2 cables
<i>Intervalo de temperaturas de funcionamiento idóneo</i>	de -20 °C a 50 °C
<i>Índice de humedad máx.</i>	85 %
<i>Cantidad de timbres</i>	6
<i>Dimensión</i>	209 x 144 x 22 cm

PLACA EXTERNA	
<i>Cámara de vídeo</i>	CMOS 420 TVL
<i>Objetivo</i>	Ángulo de visión horizontal de 100°
<i>Alimentación</i>	13 V cc incluida por el monitor
<i>Consumo máx.</i>	200 mA
<i>Luminosidad</i>	mín. 0 lux
<i>Visión nocturna</i>	de 0,5 a 1 m
<i>Dimensión</i>	157 x 72 x 27 mm
<i>Índice de protección</i>	IP44

2 - GARANTÍA

- Este producto tiene una garantía de 3 años para las piezas y la mano de obra desde la fecha de la compra. Es obligatorio conservar el justificante de compra durante todo el periodo de la garantía.
- La garantía no cubre los daños causados por negligencia, golpes o accidentes.
- Cualquier intervención en el aparato anulará la garantía.
- No seccione o alargue el cable del adaptador de red o se anulará la garantía.

dificultades durante la instalación del producto o tiene cualquier pregunta, le aconsejamos encarecidamente que se ponga en contacto con nuestros especialistas que se encuentran a su disposición para asesorarle.

- En caso de problemas de funcionamiento durante la instalación o tras unos días de uso, debe ponerse en contacto con nosotros con la instalación delante para que nuestros técnicos diagnostiquen el origen del problema, ya que este seguramente se deba a un ajuste no adaptado o a una instalación no conforme.

3 - ASISTENCIA Y ASESORAMIENTO

- A pesar de todo el cuidado que hemos aportado al diseño de nuestros productos y a la realización de estas instrucciones, si encuentra

Póngase en contacto con los técnicos de nuestro servicio posventa en el:

+ 34 902 101 633

De lunes a jueves de 8:00 a 17:00 h y los viernes de 08:00 a 13:00 h.

PT

Videofone a cores 7"

2 fios

ref.^a 340100



GARANTIA 3 anos



ECRÃ DE 7"



VISÃO
NOTURNA



TOQUES



2 FIOS



ALCANCE
100M

A - INSTRUÇÕES DE SEGURANÇA

1 - INTRODUÇÃO

Este videoporteiro combina dois módulos: um monitor recetor e um painel da rua fácil de instalar e usar.

Características principais:

- Receção de vídeo a cores: quando um visitante prime a tecla de chamada do painel da rua, esta ação transmite imediatamente a imagem ao ecrã e uma campainha assinala a sua presença.
- Proteção em caso de curto-circuito
- Proteção em caso de inversão de polaridade
- Ajuste automático da exposição: a câmara de vídeo ajusta-se automaticamente à iluminação ambiente.
- Permite controlar dois dispositivos de acesso (fechadura e comando automático).
- A visão em infravermelho integrada na câmara de vídeo permite identificar os visitantes sem necessidade de iluminação suplementar.
- Abertura de uma porta e de um comando: ao premir as teclas do monitor, pode controlar uma fechadura elétrica e um contacto seco para o comando automático (não fornecido).

IMPORTANTE: este manual deve ser lido atentamente antes da instalação. Em caso de problema, os técnicos da nossa Hotline estão disponíveis para fornecer toda a informação necessária.

ATENÇÃO: qualquer ligação incorreta pode provocar danos no aparelho e resultar na anulação da garantia.

2 - CONSERVAÇÃO E LIMPEZA

Antes de instalar o seu videoporteiro, verificar imperiosamente os pontos seguintes:

- Não instalar em condições extremas de humidade, temperatura e poeira ou em caso de risco elevado de corrosão.
- Não expor o monitor diretamente à luz do sol, chuva ou grande humidade.
- Não ligar o aparelho a uma tomada múltipla ou cabo de extensão.
- Não instalar perto de outros dispositivos eletrónicos, como um computador, um televisor ou um gravador de vídeo.
- Não instale o aparelho na proximidade de

produtos químicos ácidos, de amoníaco ou de fontes de emissão de gases tóxicos.

- Não limpar o aparelho com um produto abrasivo ou corrosivo. Utilizar um pano ligeiramente humedecido com água e sabão.
- Se quiser deixar o aparelho inativo durante um período prolongado, não se esqueça de desligá-lo.
- Não ligar o aparelho às redes nacionais de telecomunicação.

3 - RECICLAGEM



Este logótipo significa que os aparelhos inutilizados não devem ser eliminados em conjunto com o lixo doméstico.

As substâncias perigosas que é habitual conterem podem ser nocivas para a saúde e o ambiente. Peça ao seu fornecedor que recolha estes dispositivos, ou utilize os meios de recolha seletiva disponibilizados pela sua autarquia.



B - DESCRIÇÃO DO PRODUTO

1 - CONTEÚDO DO KIT

1 x1

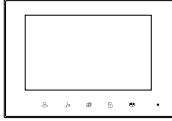

2 x1



3 x1

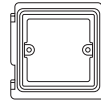

4 x5



5 x5



6 x3



7 x1



1	Monitor
2	Painel da rua
3	Suporte de parede para monitor
4	Buchas (2 para o monitor, 3 para o painel da rua)

5	Parafusos de fixação (2 para o monitor, 3 para o painel da rua)
6	Conector do painel da rua para o monitor/trinco elétrico/motorização do portão
7	Adaptador de corrente

C - INSTALAÇÃO

A altura de montagem recomendada é de cerca de 160 cm do solo para o painel da rua e 150 cm do solo para a unidade interna.

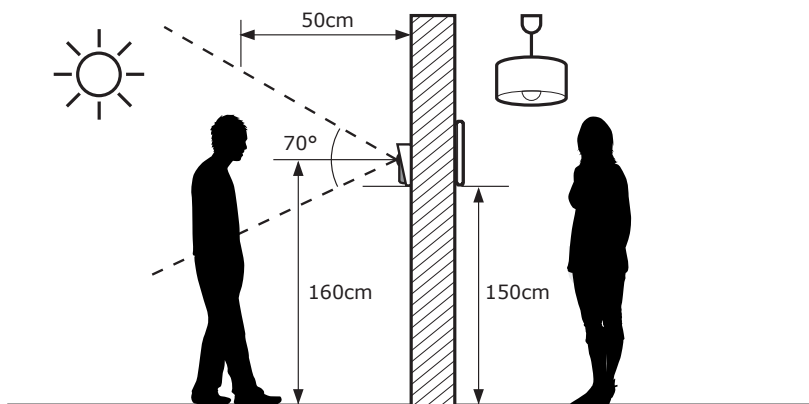

ATENÇÃO: Por motivos evidentes de segurança, as ligações apenas devem ser efetuadas após ter desligado a alimentação elétrica.

1 - INSTALAÇÃO DO PAINEL DA RUA

Fixar a tampa do painel da rua na sua coluna com a ajuda de parafusos e buchas adaptados ao suporte (os parafusos e buchas fornecidos são aconselháveis para paredes de material sólido).

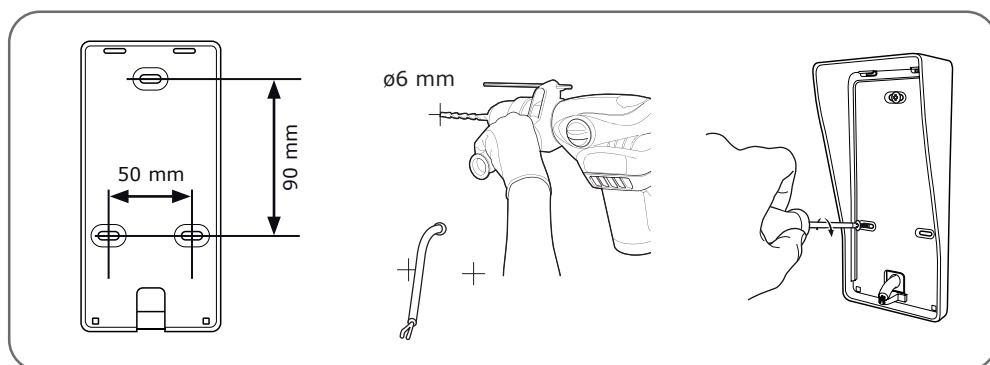

Após ter efetuado as ligações do painel da rua (ver parágrafo "ligações"), colocá-lo na sua tampa.

C - INSTALAÇÃO

Em seguida, aparafusar o painel da rua à tampa com a ajuda do parafuso fornecido.

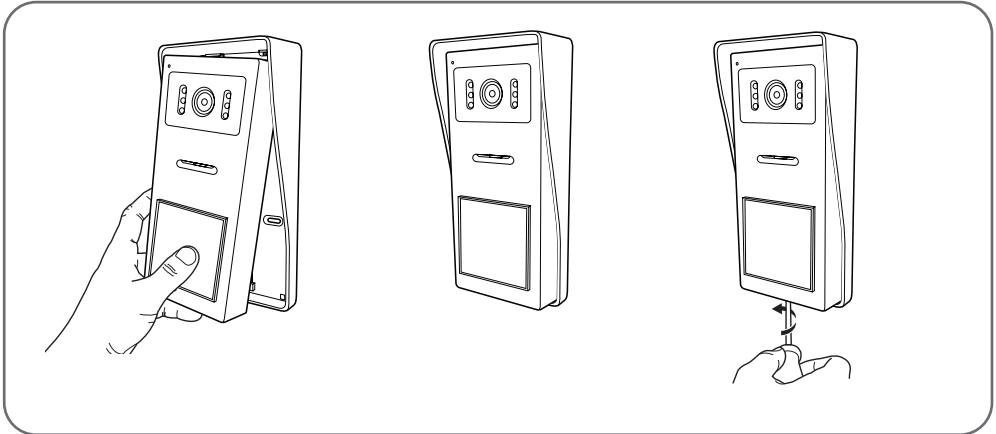

Colocar a etiqueta do nome no lugar.

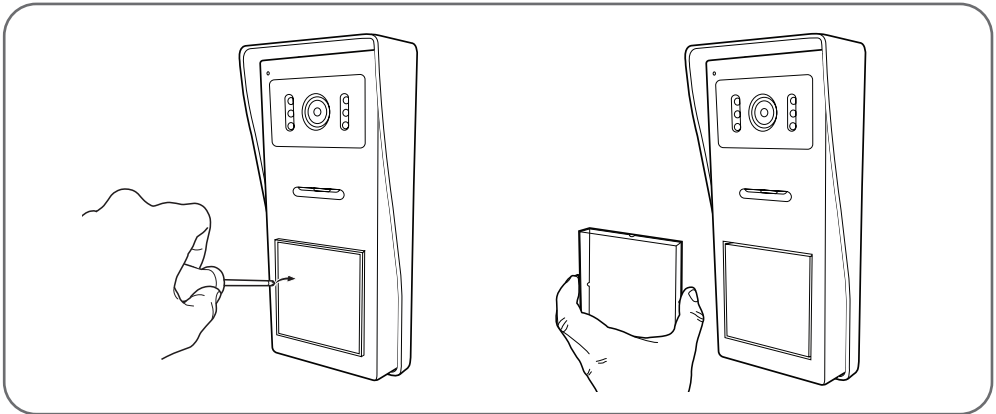

C - INSTALAÇÃO

2 - INSTALAÇÃO DO MONITOR

Fixe o suporte de parede com parafusos e buchas apropriados (os parafusos e buchas fornecidos são aconselháveis para paredes de material sólido).

Após ter efetuado as ligações do monitor (ver parágrafo "ligações"), fixar o monitor no seu suporte.

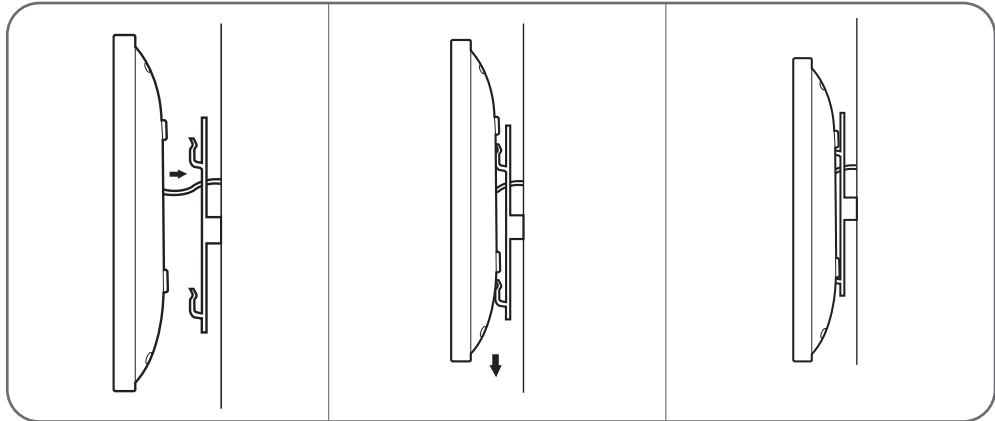
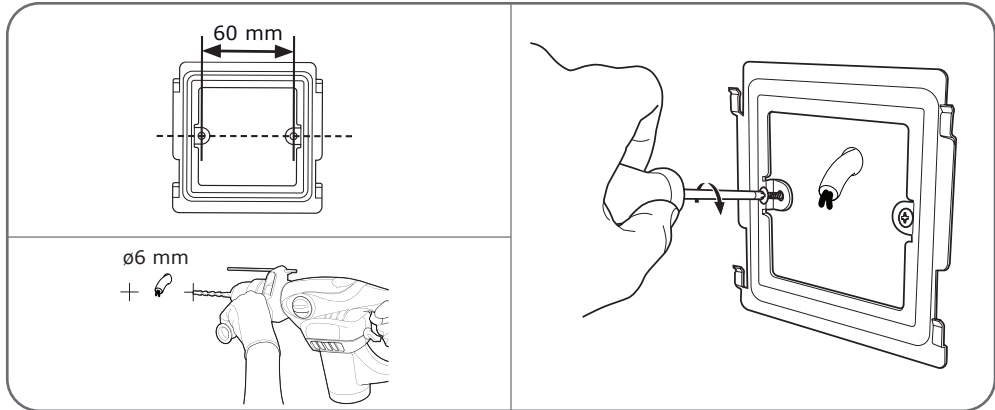

3 - AS LIGAÇÕES

- Não multiplicar as caixas de junção ou conexões no fio de ligação entre o painel da rua e o monitor
- Mantenha o fio entre o painel da rua e o monitor a mais de 50 cm de distância de qualquer interferência eletromagnética (cabo de 230 V, dispositivo WiFi, forno de micro-ondas, etc.)
- Pode conectar e usar um trinco elétrico (não fornecido) com o seu painel da rua, com ou sem memória mecânica.

C - INSTALAÇÃO

Entre o monitor e o painel da rua (100 m no máximo)

Com vista a garantir uma boa qualidade de áudio e vídeo, aconselha-se não utilizar mais de 100 m de cabo entre o videoporteiro e o painel da rua. Ligar corretamente os fios conforme se segue (uma inversão de ligação pode danificar o painel da rua).

A secção do cabo a utilizar depende do seu comprimento:

Comprimento do cabo	Secção a utilizar
De 0 a 50 m	0,75 mm ²
De 50 m a 100 m	1,5 mm ²

Entre o painel da rua e um trinco elétrico (não fornecido)

Utilizar um trinco de 12 V/1,1A no máximo com ou sem memória mecânica.

Para a ligação entre o painel da rua e o trinco, utilizar um cabo do tipo:

Comprimento do cabo	Secção a utilizar
De 0 a 50 m	0,75 mm ²

Entre o painel da rua e um portão automático (não fornecido)

Secção a utilizar: 0,75 mm² mín

3.1 - LIGAÇÃO ENTRE O MONITOR E O PAINEL DA RUA

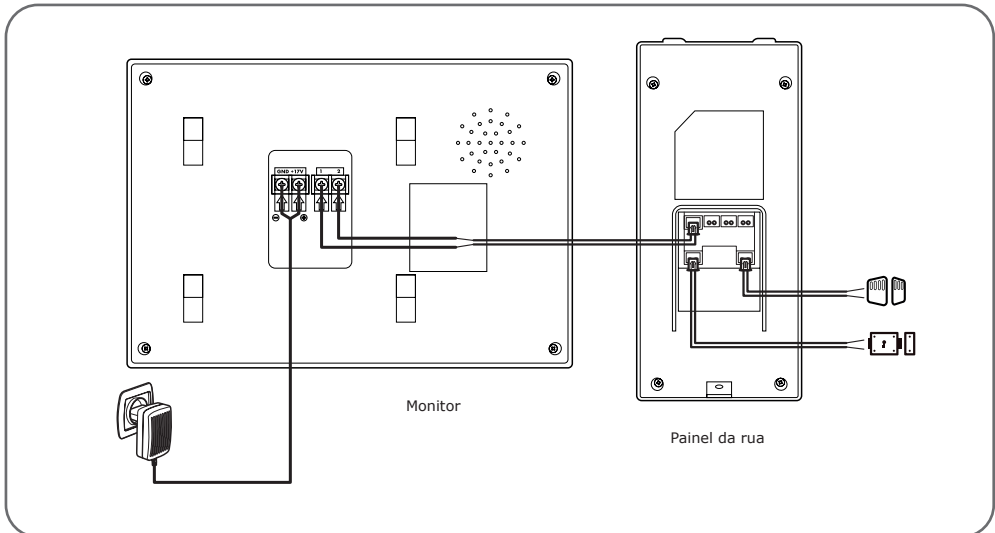

IMPORTANTE: ligue a saída do comando do portão diretamente ao contacto de abertura/fecho do comando automático (entrada de comando com fio de um motor de portão).

O seu videoporteiro está equipado com a função Polarity protect: o sentido de ligação dos dois fios do monitor, do trinco elétrico ou do portão não é relevante.

D - UTILIZAÇÃO

1 - IDENTIFICAR OS VISITANTES E FALAR COM ELES

O visitante prime o porta-nome do painel da rua:



A campainha soa pelo altifalante do monitor que ativa a câmara de vídeo do painel da rua. Se o visitante estiver no campo da câmara, a sua imagem aparecerá no monitor durante 30 segundos. No fim dos 30 segundos, o monitor volta ao modo de espera.

Para falar com o visitante, premir a tecla . Para terminar a conversa e desativar o painel da rua, premir a tecla .

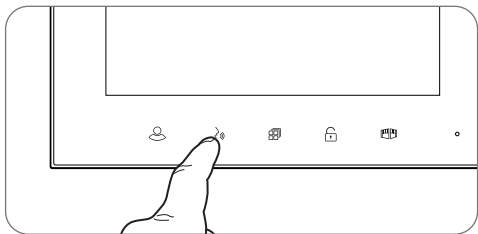

2 - ATIVAR O PAINEL DA RUA A PARTIR DO MONITOR

Para identificar discretamente um visitante ou observar simplesmente o que se passa na entrada, premir a tecla : a imagem do painel da rua aparecerá no ecrã durante 60 segundos.

Se quiser comunicar diretamente com o exterior, premir a tecla após a apresentação da imagem da câmara de vídeo externa.

Esta função particularmente útil permite observar o visitante sem pressão da tecla de chamada.

3 - ABERTURA DE UMA FECHADURA ELÉTRICA E DE UM COMANDO AUTOMÁTICO

Se o aparelho tiver uma fechadura elétrica e/ou um comando automático (ver parágrafo "Ligação"), premir a tecla (para a fechadura) ou a tecla (para o comando automático) para deixar entrar o visitante.

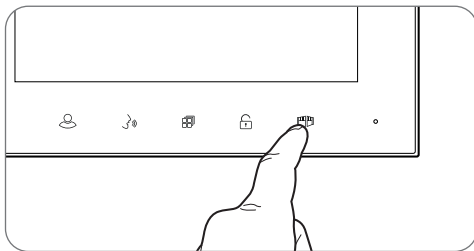
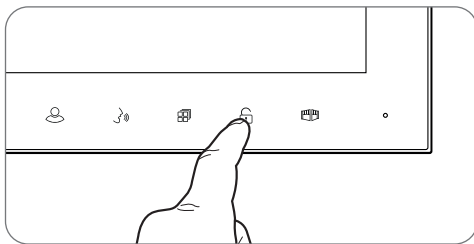

Atenção, para os comandos contacto seco e saída alimentada estarem operacionais, é necessário que o ecrã esteja aceso. Se o ecrã estiver desligado, será necessário ligá-lo premindo o botão .

E - INFORMAÇÕES TÉCNICAS E LEGAIS

1 - CARACTERÍSTICAS TÉCNICAS

MONITOR	
<i>Ecrã</i>	LCD a cores de 7 polegadas extra plano
<i>Padrão de vídeo</i>	PAL/NTSC
<i>Resolução</i>	800 x 480
<i>Alimentação</i>	Com adaptador de corrente 230 VAC 50 Hz/17 VDC 1,5 A fornecido
<i>Proteção</i>	Proteção em caso de curto-circuito e em caso de inversão de polaridade
<i>Sistema de transmissão (áudio e vídeo)</i>	2 fios
<i>Intervalo de temperatura de funcionamento ideal</i>	-20 °C a 50 °C
<i>Nível máximo de humidade</i>	85 %
<i>Número de toques</i>	6
<i>Dimensão</i>	209 x 144 x 22 cm

PAINEL DA RUA	
<i>Câmara de vídeo</i>	CMOS 420TVL
<i>Objetiva</i>	Ângulo de visão horizontal 100°
<i>Alimentação</i>	13VDC fornecida pelo monitor
<i>Consumo max.</i>	200 mA
<i>Brilho</i>	mín 0 lux
<i>Visão noturna</i>	De 0,5 a 1 m
<i>Dimensão</i>	157 x 72 x 27 mm
<i>Índice de proteção</i>	IP44

2 - GARANTIA

- Este produto tem uma garantia de 3 anos, que abrange peças e mão-de-obra, a partir da data de compra. É imperativo que guarde uma prova de compra durante esse período de garantia.
- A garantia não cobre os danos causados por negligência, choques ou acidentes.
- Qualquer intervenção no aparelho anulará a garantia.
- Cortar ou aumentar o comprimento do fio do adaptador de corrente anulará a garantia.

3 - ASSISTÊNCIA E CONSELHOS

- Apesar de todo o cuidado empregue na criação dos nossos produtos e na redação deste manual, caso tenha dificuldades durante a instalação do seu produto ou quaisquer

questões, é aconselhável contactar os nossos especialistas, que estão à sua disposição para o aconselhar.

- Caso verifique algum problema de funcionamento durante a instalação ou nos primeiros dias de utilização, é imperativo que entre em contacto connosco na presença da sua instalação para que um dos nossos técnicos faça um diagnóstico da origem do problema pois este dever-se-á, provavelmente, a uma definição não adequada ou a uma instalação não conforme.

Contacte os técnicos do nosso serviço pós-venda através do número:

707 45 11 45

De segunda a sexta-feiran entre as 9h e as 13h e entre as 14h e as 18h.

IT

Videocitofono a colori 7"

2 fili

cod. 340100



GARANZIA 3 anni



SCHERMO 7"



VISIONE
NOTTURNA



SUONERIE



2 FILI



PORTATA
100M

A - ISTRUZIONI DI SICUREZZA

1 - INTRODUZIONE

Il presente videocitofono unisce due moduli in uno: un monitor ricevitore e una pulsantiera esterna facile da installare e utilizzare.

Principali caratteristiche:

- Visualizzazione video a colori: premendo il pulsante di chiamata sulla pulsantiera esterna, l'immagine ripresa dalla telecamera è subito trasmessa al display e si avverte inoltre il suono di un campanello.
- Protezione in caso di cortocircuito
- Protezione in caso di inversione di polarità
- Regolazione automatica dell'esposizione: la telecamera si adatta automaticamente alla luce ambiente.
- Possibilità di gestire due tipi di accesso (serratura e cancello).
- Visione a infrarossi integrata per identificare chi suona senza bisogno di ulteriori luci.
- Apertura porta e cancello: premendo i tasti sul monitor è possibile azionare una serratura elettrica e un contatto pulito per cancello (non incluso).

IMPORTANTE: Leggere attentamente il presente manuale prima di eseguire l'installazione. In caso di necessità, i tecnici dell'assistenza rimangono a disposizione per informazioni.

ATTENZIONE: eventuali errori nel collegamento possono causare danni al dispositivo e invalidare la garanzia.

2 - MANUTENZIONE E PULIZIA

Prima di installare il videocitofono, controllare quanto elencato di seguito:

- Non installare in ambienti soggetti a condizioni estreme di umidità, temperatura, rischio di corrosione o presenza eccessiva di polvere.
- Non esporre il monitor alla luce diretta del sole, alla pioggia o a umidità elevata.
- Non usare prese multiple o prolunghe.
- Non installare in prossimità di altri apparecchi elettronici come computer, televisori o videoregistratori.
- Non installare in prossimità di prodotti chimici acidi, ammoniaca o fonti di emissione di gas tossici.

- Non pulire con prodotti abrasivi o corrosivi. Usare un panno leggermente inumidito con acqua e sapone.
- Se inutilizzato per un lungo periodo, scollegare il dispositivo.
- Non collegare il dispositivo a impianti di telecomunicazione pubblici.

3 - SMALTIMENTO



Questo logo indica che i dispositivi non più utilizzabili non possono essere gettati nei contenitori per i normali rifiuti.

Le sostanze tossiche che possono essere in essi contenute, infatti, possono rappresentare un rischio per la salute e per l'ambiente. Tali dispositivi devono essere resi al proprio rivenditore oppure smaltiti secondo quanto stabilito dalle autorità locali.



B - DESCRIZIONE DEL PRODOTTO

1 - CONTENUTO DEL KIT

1 x 1



2 x 1



3 x 1

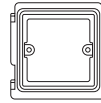

4 x 5



5 x 5



6 x 3



7 x 1



1	Monitor
2	Pulsantiera esterna
3	Supporto a parete per monitor
4	Tasselli (2 per il monitor, 3 per la pulsantiera esterna)

5	Viti di fissaggio (2 per il monitor, 3 per la pulsantiera esterna)
6	Connettore pulsantiera esterna verso monitor/serratura elettrica/motore cancello
7	Adattatore di alimentazione

C - INSTALLAZIONE

L'altezza di montaggio consigliata è di 160 cm circa da terra per la pulsantiera esterna e di 150 cm circa da terra per l'unità interna.

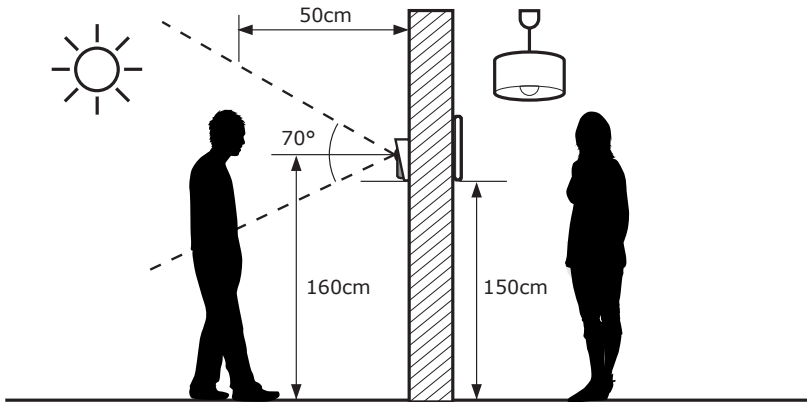

ATTENZIONE: Per motivi di sicurezza i collegamenti devono essere eseguiti solo dopo aver interrotto l'alimentazione di corrente.

1 - INSTALLAZIONE DELLA PULSANTIERA ESTERNA

Fissare la custodia con visiera della pulsantiera esterna al pilastro o al muro usando viti e tasselli adatti al tipo di supporto (le viti e i tasselli forniti sono adatti per l'uso su muri pieni).

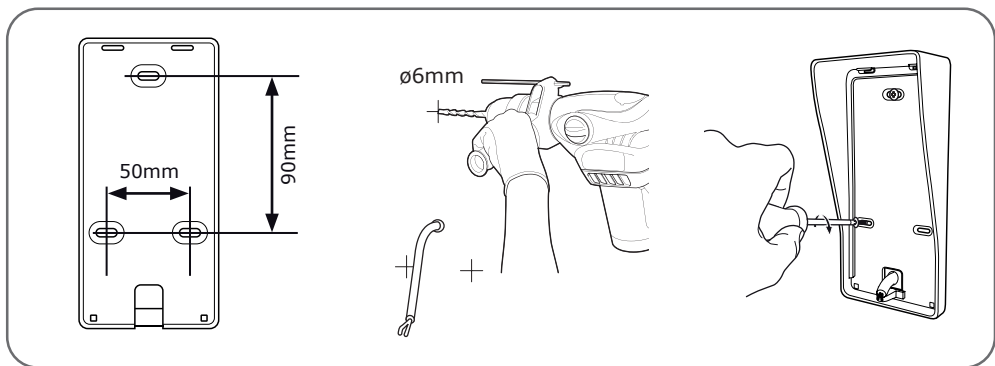

Eseguire i vari collegamenti elettrici della pulsantiera esterna (v. paragrafo "collegamenti") e disporla all'interno della custodia con visiera.

C - INSTALLAZIONE

Fissare la pulsantiera all'interno della custodia con visiera servendosi dell'apposita vite.

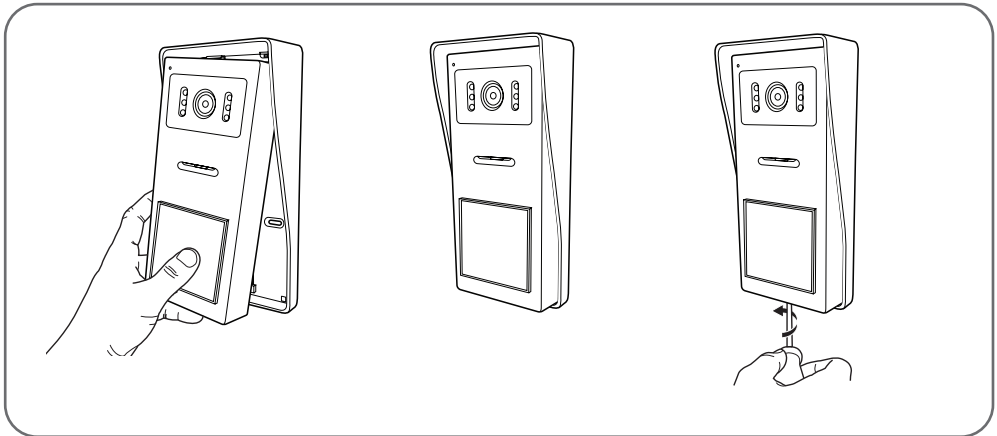

Inserire l'etichetta con il nome.

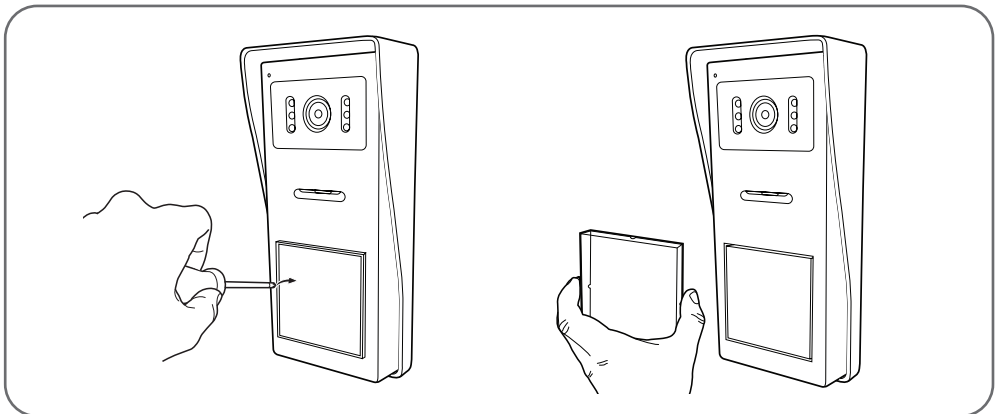

C - INSTALLAZIONE

2 - INSTALLAZIONE DEL MONITOR

Fissare il supporto murale alla parete usando viti e tasselli adatti al tipo di supporto (le viti e i tasselli forniti sono adatti per l'uso su muri pieni).

Dopo aver collegato il monitor (v. paragrafo "collegamenti"), fissare il monitor al supporto.

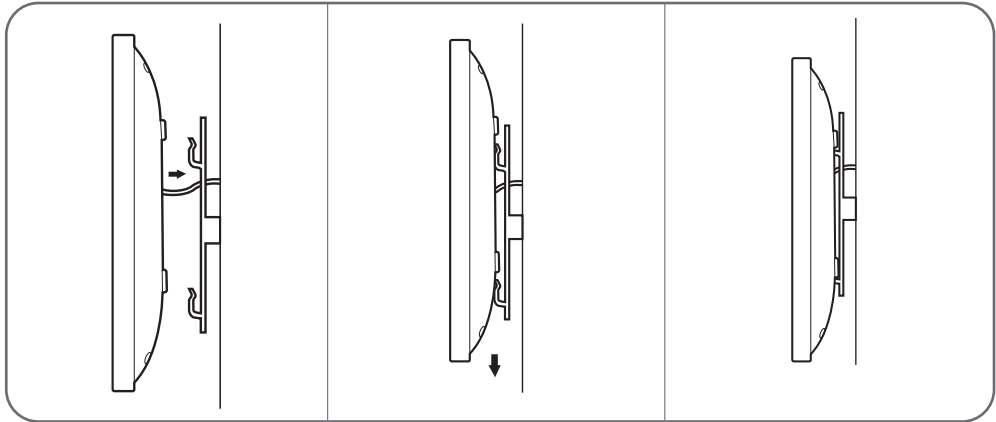
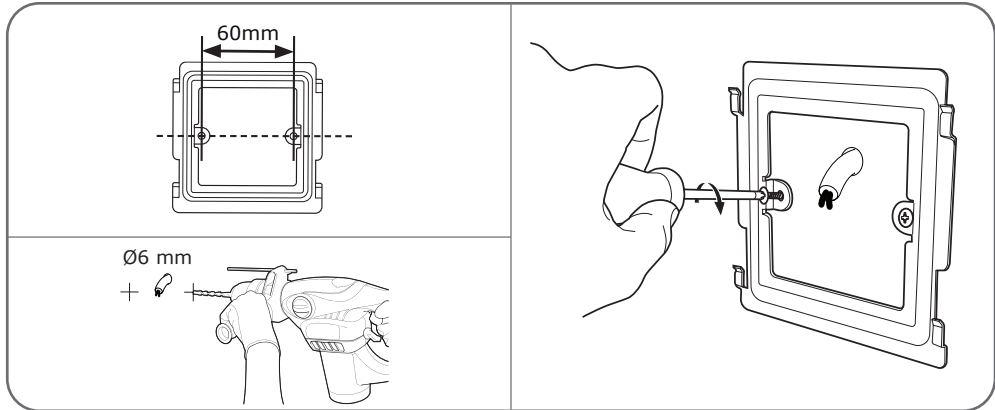

3 - COLLEGAMENTI

- Non usare più morsetti o raccordi sul filo di collegamento tra la pulsantiera esterna e il monitor
- Allontanare il filo di collegamento tra la pulsantiera esterna e il monitor di oltre 50cm da eventuali fonti di interferenza elettromagnetica (cavi 230V, dispositivi Wi-Fi, forni a microonde, ecc.)
- Possibilità di collegare alla pulsantiera esterna una bocchetta elettrica (non inclusa) con o senza memoria meccanica.

C - INSTALLAZIONE

Tra il monitor e la pulsantiera esterna (100m max.)

Per garantire una qualità audio/video ottimale, si consiglia di non utilizzare cavi di più di 100m tra il videocitofono e la pulsantiera esterna. Collegare i fili facendo attenzione a rispettare quanto indicato di seguito (un eventuale inversione dei cavi potrebbe danneggiare la pulsantiera esterna).

La sezione del cavo da utilizzare dipende dalla lunghezza dello stesso:

Lunghezza cavo	Sezione da utilizzare
Da 0 a 50m	0,75mm ²
Da 50m a 100m	1,5mm ²

Tra la pulsantiera esterna e la serratura elettrica (non inclusa)

Usare una bocchetta 12V/1,1A max. con o senza memoria meccanica.

Per il collegamento tra la pulsantiera esterna e la serratura elettrica usare un cavo con le caratteristiche seguenti:

Lunghezza cavo	Sezione da utilizzare
Da 0 a 50m	0,75mm ²

Tra la pulsantiera esterna e l'automatismo per cancello (non incluso)

Sezione da utilizzare: 0,75mm² min.

3.1 - COLLEGAMENTO TRA IL MONITOR E LA PULSANTIERA ESTERNA

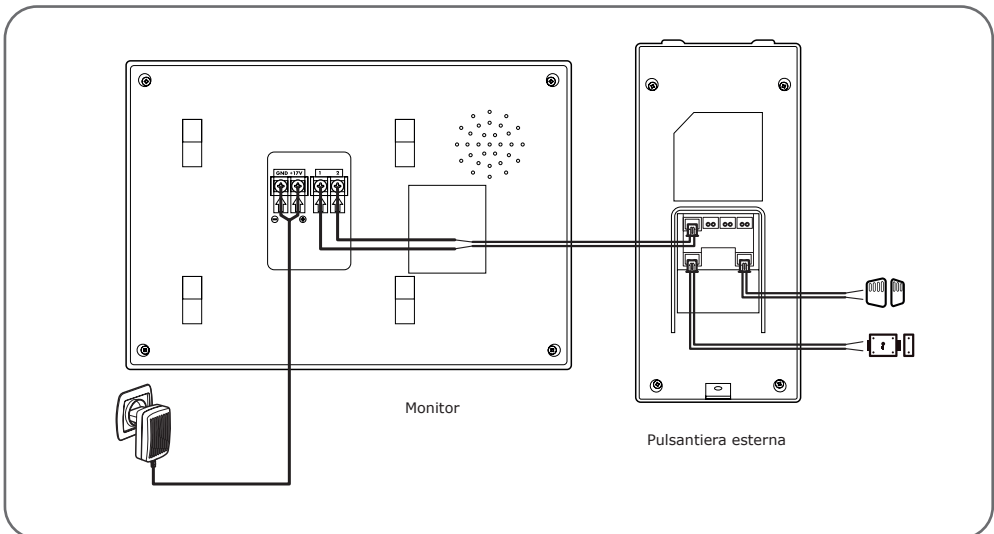

IMPORTANTE: collegare l'uscita di comando cancello direttamente al contatto di apertura/chiusura del cancello (ingresso comando filare cancello motorizzato).

Il videocitofono è dotato della funzione Polarity Protect: il senso di collegamento dei due fili del monitor, della serratura elettrica e del cancello è indifferente.

D - UTILIZZO



1 - IDENTIFICARE CHI HA SUONATO E COMUNICARE

Il portanome è premuto sulla pulsantiera esterna:



Il campanello suona attraverso l'altoparlante del monitor, attivando la telecamera della pulsantiera esterna. Se chi ha suonato si trova all'interno del campo visivo della telecamera, la sua immagine sarà visualizzata sul monitor per 30 secondi. Dopo 30 secondi

il monitor tornerà in stand-by.

Per parlare con chi ha suonato, premere il tasto . Per terminare la conversazione e disattivare la pulsantiera esterna, premere il tasto .

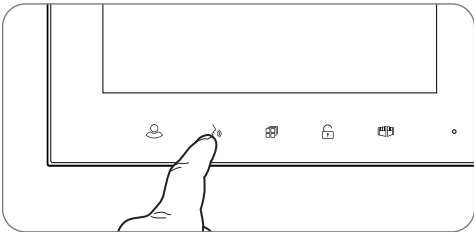



2 - ATTIVARE LA PULSANTIERA ESTERNA A PARTIRE DAL MONITOR

Per identificare chi ha suonato senza farsi vedere o semplicemente per guardare fuori, premere il tasto : sullo schermo verranno visualizzate le immagini riprese dall'esterno per 60 secondi.

Se si desidera comunicare direttamente con l'esterno, premere il tasto  quando sono visualizzate le immagini riprese dall'esterno.

Questa funzione è particolarmente utile, perché consente di osservare chi si trova davanti al citofono anche se non ha suonato.

3 - APERTURA SERRATURA ELETTRICA E CANCELLO

Se è presente una serratura elettrica e/o un cancello (v. paragrafo "Collegamenti"), premere il tasto  (per la serratura) o il tasto  (per il cancello) per lasciar entrare chi ha suonato.

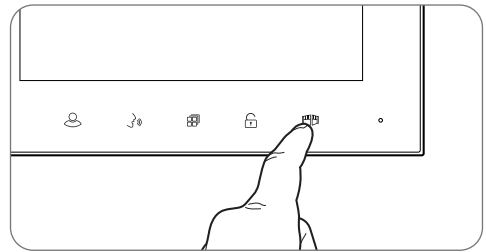
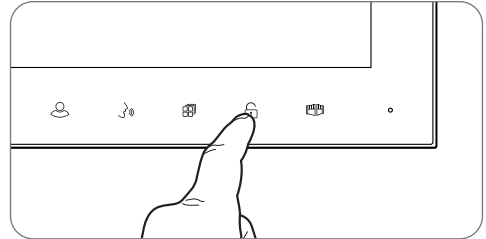

Attenzione, è necessario che lo schermo sia acceso affinché il comando contatto pulito e uscita alimentata siano operativi. Se lo schermo è spento è necessario accenderlo tramite il pulsante .

D - UTILIZZO



4 - IMPOSTAZIONI SUL MONITOR

Quando il monitor è acceso, premendo il tasto  viene visualizzata la schermata seguente:

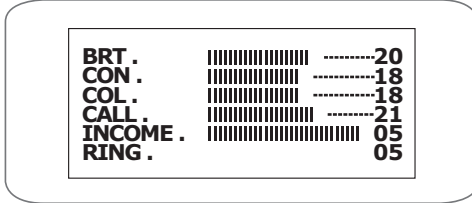

Navigare nei sottomenù premendo sui tasti 



• BRT:

Luminosità: premere i tasti  e  per ridurre o aumentare il livello di luminosità dell'immagine.

• CON:

Contrasto: premere i tasti  e  per ridurre o aumentare il livello di contrasto dell'immagine.

• COL:

Colore: premere i tasti  e  per ridurre o aumentare il livello di saturazione dell'immagine.

• CALL:

Volume microfono: premere i tasti  e 

per aumentare o ridurre il volume del microfono.

• INCOME:

Volume campanello: premere i tasti  e 

per ridurre o aumentare il volume della suoneria del citofono.

• RING:

Selezione campanello: premere i tasti  e

 per selezionare la suoneria desiderata.

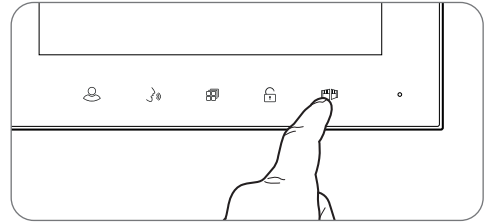

Una volta nel sottomenu RING, premere il tasto  per uscire.

E - NOTE TECNICHE E LEGALI

1 - CARATTERISTICHE TECNICHE

MONITOR	
Schermo	a colori 7 pollici LCD ultrapiatto
Standard video	PAL/NTSC
Risoluzione	800 x 480
Alimentazione	Con adattatore di alimentazione 230 VAC 50 Hz/17 VDC 1,5 A incluso
Protezione	Protezione in caso di cortocircuito e inversione di polarità
Sistema di trasmissione (audio e video)	2 fili
Range temperatura di funzionamento ideale	Da -20 °C a 50 °C
Tasso di umidità max.	85 %
Numero di suonerie	6
Misure	209 x 144 x 22 cm

PULSANTIERA ESTERNA	
Telecamera	CMOS 420TVL
Obiettivo	Angolo di visione orizzontale 100°
Alimentazione	13 VDC tramite monitor
Consumo max.	200 mA
Luminosità	min. 0 lux
Visione notturna	Da 0,5 a 1 m
Misure	157 x 72 x 27 mm
Grado di protezione	IP44

2 - GARANZIA

- Il presente prodotto è coperto da una garanzia pezzi e manodopera di 3 anni a partire dalla data di acquisto. Per far valere la garanzia è necessario conservare la prova di acquisto.
- La garanzia non copre eventuali danni dovuti a negligenza, urti o incidenti.
- Eventuali interventi di riparazione autonomi del prodotto invalidano la garanzia.
- Non tagliare o prolungare il cavo dell'adattatore AC/DC, pena l'annullamento della garanzia.

3 - ASSISTENZA E CONSIGLI

- Nonostante tutta la cura con la quale abbiamo progettato i nostri prodotti e realizzato il presente manuale, qualora l'utente incontri difficoltà nell'installare il prodotto o abbia dei dubbi è

invitato a contattare i nostri specialisti, che saranno sempre a sua completa disposizione per rispondere a tutte le sue domande.

- In caso di malfunzionamento del prodotto durante l'installazione o pochi giorni dopo la stessa, si invita a contattare l'assistenza clienti rimanendo in prossimità del prodotto, in modo da consentire ai tecnici di diagnosticare subito l'origine del problema, con molta probabilità dovuto a errato settaggio o installazione non conforme.

I tecnici del nostro servizio post-vendita sono disponibili al numero:

+ 39 02 97 27 15 98

Dal lunedì al venerdì dalle 9:00 alle 13:00 e dalle 14:00 alle 18:00.



Avidsen
19 Avenue Marcel Dassault
ZAC des Deux Lions - 37200 Tours - France